

**TECHNICAL MANUAL**

**DIRECT SUPPORT AND GENERAL  
SUPPORT MAINTENANCE MANUAL**

**FOR**

**LAND MINES**

Distribution A: Approved for public release; distribution is unlimited.

---

HEADQUARTERS, DEPARTMENT OF THE ARMY

November 1993

**WARNINGS**

Use only electrical equipment with national electrical code rating of class I for flammable vapor; class II for explosive dusts (including ammunition) or with dual rating if both vapor and dusts are present.

Store rags in noncombustible self-closing containers. Place waste or used rags in water-filled containers. Assure that areas in which solvents are used are well ventilated.

Wear respirator during spray paint operations.

**THIS PAGE INTENTIONALLY LEFT BLANK**

CHANGE )  
 )  
 NO. 3 )

HEADQUARTERS  
 DEPARTMENT OF THE ARMY  
 WASHINGTON, DC, 19 October 2006

**Direct Support and General Support Maintenance Manual  
 for  
 Land Mines**

DISTRIBUTION STATEMENT A - Approved for public release; distribution is unlimited.

TM 9-1345-203-34, 29 November 1993, is changed as follows:

1. File this change sheet after the Warning Summary for reference purposes.
2. Remove old pages and insert new pages as indicated below.
3. New or changed material is indicated by a vertical bar in the outer margin of the page.
4. Added or revised illustrations are indicated by a vertical bar adjacent to the illustration identification number.
5. Added or revised appendixes are indicated by a vertical bar adjacent to the appendix title.

Remove Pages

None  
 A and B  
 i and ii  
 1-1 and 1-2  
 2-3 and 2-4  
 2-9 and 2-10  
 3-1 and 3-2  
 3-7 and 3-8  
 4-1 and 4-2  
 A-1 and A-2  
 DA Form 2028-2

Insert Pages

a and b  
 A and B  
 i and ii  
 1-1 and 1-2  
 2-3 and 2-4  
 2-9 and 2-10  
 3-1 and 3-2  
 3-7 and 3-8  
 4-1 and 4-2  
 A-1 and A-2  
 DA Form 2028

By Order of the Secretary of the Army:

Official:

  
 JOYCE E. MORROW  
 Administrative Assistant to the  
 Secretary of the Army  
 0613805

PETER J. SCHOOMAKER  
 General, United States Army  
 Chief of Staff

DISTRIBUTION: To be distributed in accordance with the initial distribution number 401069 requirements for TM 9-1345-203-34.

CHANGE

NO. 2

HEADQUARTERS  
DEPARTMENT OF THE ARMY  
Washington, DC, 30 April 2002

TECHNICAL MANUAL  
DIRECT SUPPORT AND GENERAL SUPPORT  
MAINTENANCE MANUAL  
FOR  
LAND MINES

DISTRIBUTION STATEMENT A: Approved for public release; distribution is unlimited.

TM 9-1345-203-34, dated 29 November 1993 is changed as follows:

1. File this change sheet in front of the publication for reference purposes.
2. Remove old pages and insert new pages as indicated below.
3. New or changed material is indicated by a vertical bar in the outer margin of the page.
4. Added or revised illustrations are indicated by a vertical bar adjacent to the illustration identification number.

**Remove pages**

A and B  
2-5 and 2-6

**Insert pages**

A and B  
2-5 and 2-6

By Order of the Secretary of the Army:

Official:

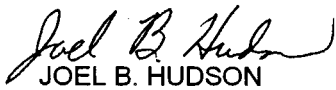

JOEL B. HUDSON  
*Administrative Assistant to the  
Secretary of the Army*

0210703

ERIC K. SHINSEKI  
*General, United States Army  
Chief of Staff*

Distribution:

To be distributed in accordance with the initial distribution number 401069, with requirements for TM 9-1345-203-34.

CHANGE )  
 )  
 No. 1 )

HEADQUARTERS  
 DEPARTMENT OF THE ARMY  
 Washington, DC, 5 May 1994

TECHNICAL MANUAL  
 DIRECT SUPPORT AND GENERAL SUPPORT  
 MAINTENANCE MANUAL  
 FOR  
 LAND MINES

TM 9-1345-203-34, 29 November 1993, is changed as follows:

1. Remove old pages and insert new pages as indicated below. New or changed material is indicated by a vertical bar in the margin of the page. Added or revised illustrations are indicated by a vertical bar adjacent to the identification number.

Remove pages

A and B  
 B-1 thru B-6

Insert pages

A and B  
 B-1 thru B-6

2. File this change sheet in front of the publication for reference purposes.

By Order of the Secretary of the Army:

GORDON R. SULLIVAN  
*General, United States Army*  
*Chief of Staff*

Official:

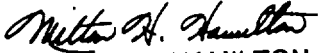
  
 MILTON H. HAMILTON  
*Administrative Assistant to the*  
*Secretary of the Army*  
 06696

Distribution:

To be distributed in accordance with DA Form 12-40-E, Block 1069, requirements for TM 9-1345-203-34.

**LIST OF EFFECTIVE PAGES**

INSERT LATEST CHANGED PAGES. DESTROY SUPERSEDED PAGES.

NOTE The portion of the text affected by the changes is indicated by a vertical line in the outer margins of the page. Changes to illustrations are indicated by a vertical line adjacent to the identification number.

Dates of issue for original and changed pages are:

Original . . . . . 0 . . . . . 29 November 1993                      Change . . . . . 2 . . . . . 30 April 2002  
 Change . . . . . 1 . . . . . 5 May 1994                              Change . . . . . 3 . . . . . 19 Oct 2006

TOTAL NUMBER OF PAGES IN THIS PUBLICATION IS 47, CONSISTING OF THE FOLLOWING:

Page No.	*Change No.	Page No.	*Change No.	Page No.	*Change No.
Cover	0				
a and b	3				
A	3				
B	0				
i	3				
ii	0				
1-1	3				
1-2	0				
2-1 thru 2-3	0				
2-4	3				
2-5	0				
2-6	2				
2-7 and 2-8	0				
2-9	3				
2-10	0				
3-1 and 3-2	3				
3-3 thru 3-7	0				
3-8	3				
4-1	3				
4-2	0				
A-1 and A-2	3				
B-1	0				
B-2 thru B-5	1				
B-6	0				
C-1 thru C-10	0				

\*Zero in this column indicates an original page

**THIS PAGE INTENTIONALLY LEFT BLANK**



**TECHNICAL MANUAL**

**No. 9-1345-203-34**

**HEADQUARTERS  
DEPARTMENT OF THE ARMY  
Washington, DC, 29 NOVEMBER 1993**

**Direct Support and General Support Maintenance Manual  
for  
Land Mines**

**REPORTING ERRORS AND RECOMMENDING IMPROVEMENTS**

You can help improve this manual. If you find any mistakes or if you know of a way to improve the procedures, please let us know. Mail your letter or DA Form 2028 (Recommended Changes to Publications and Blank Forms) located in the back of this manual directly to Logistics Research and Engineering Directorate (AMSRD-AAR-AIL-LS), U.S. Army RDECOM, Armament Research, Development and Engineering Center, Picatinny Arsenal, NJ 07806-5000. You may also send in your recommended changes via electronic mail or by fax. Our e-mail address is LSB@PICA.ARMY.MIL. Our fax number is DSN 880-4633, Commercial (973) 724-4633. A reply will be furnished to you.

		Page
CHAPTER 1	INTRODUCTION . . . . .	1-1
Section I	General . . . . .	1-1
	1-1. Scope . . . . .	1-1
	1-2. Special Tools and Equipment . . . . .	1-1
	1-3. Fabricated Tools and Equipment . . . . .	1-1
	1-4 Forms, Records, and Reports . . . . .	1-1
Section II	Safety, Care, and Handling . . . . .	1-1
	1-5. Safety, Care, and Handling . . . . .	1-1
	1-6. Explosive Ordnance Disposal . . . . .	1-1
CHAPTER 2	INSPECTION REQUIREMENTS . . . . .	2-1
Section I	General . . . . .	2-1
	2-1. Purpose of Inspection . . . . .	2-1
	2-2. Ammunition Surveillance . . . . .	2-1
	2-3. Inspections . . . . .	2-1
Section II	Classification of Material Defects . . . . .	2-1
	2-4. General . . . . .	2-1
Section III	Inspection Methods . . . . .	2-8
	2-5. General . . . . .	2-8
Section IV	Disposition of Lots . . . . .	2-9
	2-6. General . . . . .	2-9
CHAPTER 3	DIRECT SUPPORT MAINTENANCE . . . . .	3-1
Section I	Introduction . . . . .	3-1
	3-1. General . . . . .	3-1
	3-2. Direct Support Maintenance . . . . .	3-1
Section II	Cleaning . . . . .	3-1
	3-3. General . . . . .	3-1
	3-4. Procedure . . . . .	3-2
Section III	Repair . . . . .	3-2
	3-5. Packing Materials . . . . .	3-2
	3-6. Procedure . . . . .	3-2
	3-7. Alternate Procedure . . . . .	3-2

CHAPTER 3 - Continued

Section IV	Touchup, Painting, and Marking . . . . .	3-3
	3-8. Touchup . . . . .	3-3
	3-9. Painting . . . . .	3-3
	3-10. Color Coding of Boxes with Light Loads. . . . .	3-6
	3-11. Marking. . . . .	3-7
CHAPTER 4	GENERAL SUPPORT MAINTENANCE. . . . .	4-1
Section I	Introduction. . . . .	4-1
	4-1. General . . . . .	4-1
	4-2. General Support Maintenance. . . . .	4-1
Section II	Repair Parts, Special Tools and Equipment and Expendable Supplies . . . . .	4-1
	4-3. Maintenance Repair Parts . . . . .	4-1
	4-4. Tools and Equipment . . . . .	4-1
	4-5. Special Tools and Equipment . . . . .	4-1
	4-6. Expendable Supplies. . . . .	4-1
Section III	Procedures. . . . .	4-1
	4-7. Cleaning . . . . .	4-1
	4-8. Repair . . . . .	4-1
	4-9. Touchup, Painting, and Marking . . . . .	4-1
	4-10. Barrier Bags . . . . .	4-1
APPENDIX A	REFERENCES. . . . .	A-1
APPENDIX B	EXPENDABLE AND DURABLE ITEMS LIST . . . . .	B-1
APPENDIX C	MARKING INFORMATION FOR LAND MINES . . . . .	C-1

**LIST OF ILLUSTRATIONS**

Number	Title	Page
3-1	Repairing loops on wirebound box. . . . .	3-4
C-1	Typical marking diagram for fiber containers. . . . .	C-2
C-2	Typical marking diagram for metal containers. . . . .	C-3
C-3	Typical marking diagram for wooden boxes. . . . .	C-3
C-4	Typical markings for service APERS mines. . . . .	C-4
C-5	Typical markings for practice APERS mines. . . . .	C-5
C-6	Typical markings for service AT mines. . . . .	C-5
C-7	Typical markings for practice AT mines. . . . .	C-6
C-8	Typical markings for fiber containers. . . . .	C-7
C-9	Typical markings for metal containers. . . . .	C-8
C-10	Typical markings for wooden boxes. . . . .	C-8
C-11	Typical markings for mine, antipersonnel: M86. . . . .	C-9
C-12	Typical markings for shipping and storage containers, PA19 . . . . .	C-10

**LIST OF TABLES**

Number	Title	Page
2-1	Classification of Material Defects . . . . .	2-1

# CHAPTER 1 INTRODUCTION

## SECTION I. GENERAL

### 1-1. Scope.

a. These instructions apply to land mines and are for use by direct support (DS) and general support (GS) personnel.

b. Operating instructions, operator and organizational level maintenance procedures, and the Maintenance Allocation Chart (MAC) are contained in TM 9-1345-203-12. Authorized procedures, by level of maintenance, are coded (C, O, F, D) in the MAC.

c. The MAC assigns authorized maintenance functions to the lowest available maintenance level based on the following considerations:

- (1) Skills available.
- (2) Time required.
- (3) Tools and test equipment authorized.

Deviation from maintenance operations as allocated in the MAC is authorized only on approval of the Army commander representative.

d. Unserviceable items and those items included in the Repair Parts and Special Tools List (RPSTL) may be replaced at the lowest level indicated in the MAC chart.

e. Tools and equipment generally applicable to land mines are authorized for issue by tables of allowances (TA) and tables of organization and equipment (TOE). Tools, equipment and repair parts, in addition to those available to the using organization, are supplied to DS and GS maintenance units as required.

### 1-2. Special Tools and Equipment.

Special tools required for maintenance are listed in SC 9999-01-SKO and TM 9-1345-203-12.

### 1-3. Fabricated Tools and Equipment.

Local fabrication of tools and equipment is not authorized.

### 1-4. Forms, Records, and Reports.

Department of the Army maintenance forms and reporting procedures are prescribed in DA Pam 750-8, AR 700-19, and SB 742-1. Accidents Involving injury to personnel or damage to material will be reported on DA Form 285 (U.S. Army Accident Report) in accordance with AR 385-40. Explosive ammunition malfunctions will be reported in accordance with AR 75-1.

## SECTION II. SAFETY, CARE, AND HANDLING

### 1-5 Safety, Care, and Handling.

Safety, care, and handling requirements are given in AR 385-64, DA Pam 385-64, and TM 9-1345-203-12.

### 1-6 Explosive Ordnance Disposal.

Explosive ordnance disposal (EOD) includes detection, identification, render safe, recovery, evaluation, and disposal

of land mines, which constitute a hazard to personnel, installations, materiel or operations. EOD also includes disposal of explosive items considered hazardous because of damage or deterioration when destruction is beyond the capabilities of personnel normally assigned for this work. EOD units also provide assistance in the destruction of ammunition to prevent capture by the enemy and in the destruction of captured ammunition.

**THIS PAGE INTENTIONALLY LEFT BLANK**

**CHAPTER 2  
INSPECTION REQUIREMENTS**

**Section I. GENERAL**

**2-1. Purpose of Inspection**

a. Inspection, by a quality assurance specialist (Ammunition Surveillance) or by military personnel (MOS 55X40) under the guidance of the quality assurance specialist, is performed to determine item serviceability. Accordingly, criteria are provided to assure that all maintenance performed will restore the item(s) to an acceptable quality level.

b. A complete plan of all maintenance actions and a standing operating procedure (SOP) that contains detailed production techniques, standards, and controls for reducing a quality product are required. See TM 9-1300-250 for planning procedures and SOP preparation.

c. The inspection report includes maintenance required for unserviceable materiel.

**2-2. Ammunition Surveillance**

The primary purpose of surveillance is to determine ammunition serviceability. See AR

702-6, AR 740-1, AR 702-12, and SB 742-1 for policies, responsibilities, and procedures applicable to the Ammunition Surveillance and Quality Evaluation Program.

**2-3. Inspections**

a. Types of inspection include, as a minimum, premaintenance inspection (conducted during the unpacking operation); in-process inspection (during maintenance procedures); and final acceptance inspection.

b. Items packed in barrier bags, jungle wrap, or sealed cans are not to be inspected during serviceability inspection unless the sealed package has been opened or damage is suspected. In-process inspection and final acceptance inspection are required for all processed items (ammunition and packing materials) and as an integral part of all maintenance procedures.

c. Fuzes in closed, sealed containers will not be opened for inspection unless damage is visible or suspected.

**Section II. CLASSIFICATION OF MATERIAL DEFECTS**

**2-4. General**

Categories of defects are defined in SB 742-1. Ammunition and packaging defects, listed in

table 2-1, determine the method of inspection required during maintenance. An Acceptable Quality Level (AQL) established for each defect, also in table 2-1, is provided for evaluation during final acceptance inspection.

Table 2-1. Classification of Material Defects

Item or component	Category	Defect	Method of inspection	AQL
<b>GENERAL PACKAGING</b>				
Outer Container	Major	Damaged, weathered, or rotted to extent contents are not protected or container is no longer structurally sound	Visual	0.40
	Major	Container cap or closure insecure to extent contents are not protected	Visual/ manual	0.40
	Major	Contents loose to extent item may be damaged in handling	Visual/ manual	0.40
	Minor	Hardware or banding loose, missing, broken, or ineffective	Visual/ manual	0.65
	Minor	Handle or cleat missing or broken	Visual	0.65

Table 2-1. Classification of Material Defects - Continued

Item or component	Category	Defect	Method of inspection	AQL
GENERAL PACKAGING - Continued				
Inner Container	Major	Damaged to extent contents are not protected or cannot be readily removed	Visual/manual	0.40
	Major	Barrier bag improperly sealed, torn, cut, or otherwise penetrated	Visual	0.40
	Minor	Wet (except metal), moldy, or mildewed	Visual	0.65
	Minor	Barrier bag edges delaminating but not yet sealed	Visual	0.65
WOODEN BOXES AND CRATES				
Hardware	Minor	Inoperative or loose	Visual/manual	0.65
	Minor	Nails, screws, and fasteners which can be replaced or properly sealed	Visual	0.65
Ends	Major	Damage which requires disassembly of box	Visual	0.40
	Minor	Broken or missing cleats and handles	Visual	0.65
Wood	Major	Splits closer than 1 inch to edge of board or adjoining split or over 1/8-inch wide	Visual	0.40
	Major	Warping which prevents insertion or removal of mines and/or sealing of the box	Visual/manual	0.40
	Major	Excessive mildew and mold which cannot be removed and which render markings illegible	Visual	0.40
	Major	Holes or loose knots which exceed 1 1/2 inches in largest diameter or 1/3 width of board	Visual	0.40
	Major	Knots greater than 1/4 the width of the skid	Visual	0.40
	Minor	Splits over 3 inches but no closer than 1 inch to edge of board or adjoining split; or 1/8-inch wide, which can be repaired by use of corrugated fasteners	Visual	0.65
	Minor	Loose skids	Visual	0.65
Strapping	Minor	Missing, rusted, or distorted	Visual	0.65
Wires	Major	Broken or rusted through	Visual	0.40
Marking	Major	Incorrect and/or illegible	Visual	0.40
FIBER CONTAINERS				
Metal ends	Major	Perforations, excessive rust, or ends which are crushed or not securely crimped to body	Visual	0.40

**Table 2. Classification of Material Defects - Continued**

Item or component	Category	Defect	Method of Inspection	AQL
FIBER CONTAINERS - Continued				
Body and cap	Major	Cuts, tears, or gouges, closer than 1 inch to closure, more than 1/2 square inch in area, or through all impregnated layers	Visual	0.40
	Major	Molded, mildewed, or rotted	Visual	0.40
	Major	Wrinkled or peeling	Visual	0.40
	Major	Blisters with combined area of more than 1/2 square inch	Visual	0.40
	Major	Wet or soft containers	Visual/ manual	0.40
	Minor	Cuts, tears, or gouges less than 1/2 square inch in area, but not through all impregnated layers	Visual	0.65
Marking	Major	Incorrect and/or illegible	Visual	0.40
METAL CONTAINERS				
Body	Major	Dents which impair the structural integrity of the material	Visual	0.40
	Major	Loose or leaking seams	Visual	0.40
	Major	Rust which has caused pitting and perforations	Visual	0.40
	Minor	Dents deeper and 1/4 inch which may be removed without weakening structure of container	Visual	0.65
	Minor	Minor rust which can be removed	Visual	0.65
	Minor	Supports which can be replaced	Visual	0.65
Caps and covers	Major	Rust which has caused excessive pitting	Visual	0.40
	Major	Perforated	Visual	0.40
	Minor	Minor rust which can be removed	Visual	0.65
Marking	Major	Incorrect and/or illegible	Visual	0.40
METAL BOXES				
Body and cover	Major	Extensive pitting and rust	Visual	0.40
	Major	Split seams	Visual	0.40
	Major	Dents which cause creases or folds in metal which cannot be removed	Visual	0.40
	Major	Perforated	Visual	0.40
	Major	Missing or broken separators	Visual	0.40
	Minor	Minor rust which can be removed	Visual	0.65

**Table 2. Classification of Material Defects - Continued**

Item or component	Category	Defect	Method of Inspection	AQL
METAL BOXES - Continued				
Body and cover (cont)	Minor	Dents exceeding 4 square inches per side, end, or top or deeper than 1/4 inch	Visual	0.65
	Minor	Damaged or missing gaskets	Visual	0.65
Marking	Major	Incorrect and/or illegible	Visual	0.40
SERVICE ANTIPERSONNEL MINES				
Mine, Apers: M14	Critical	Pressure plate not in safe position (arrowhead not pointing to S)	Visual	
		Safety clip missing or insecure	Visual	
		Arrowhead on pressure plate or letter S on fuze body missing or illegible	Visual	
		Pressure plate in fired position (firing pin extends into detonator well)	Visual	
	Major	Shipping plug turns when force of 1 in. lb is applied in loosening direction	Manual/gauge	0.40
		Gap between fuze body and mine body (indicating incorrect assembly)	Visual	0.40
Firing pin missing or damaged		Visual	0.40	
Components missing or defective	Visual	0.40		
Mine, APERS: M16 Series (M16, M16A1, M16A2) with Fuze, Mine, Combination M605	Critical	Interlocking safety pin, striker safety pin, or safety pin assembly missing or not interlocked	Manual/visual	
		Release cotter pin missing	Visual	
		Prong not bent		
	Major	Shipping plug missing or loose	Manual/visual	0.65
		Top of container inadequately secured to its side	Visual	0.65
Container assembly damaged (punctured, dented, cracked)	Visual	0.65		
Components missing	Visual	0.65		
Mine, APERS, M18A1 with Electric Initiation System	Critical	None listed		
	Major	Shipping plug adapter missing, damaged, or improperly assembled	Manual/visual	1.0
		Leg assembly twisted, bent, or otherwise damaged	Visual	1.0
		Components missing	Visual	0.65
Tag damaged or missing from bandoleer containing test set	Visual	0.65		
Mine, APERS, M18A1 with Non-electric Initiation System	Critical	None listed		
	Major	Shipping plug adapter missing, damaged, or improperly assembled	Manual/visual	1.0
		Leg assembly twisted, bent, or otherwise damaged	Visual	1.0
Components missing	Visual	0.65		



Table 2-1. Classification of Material Defects - Continued

Item or component	Category	Defect	Method of inspection	AQL
SERVICE ANTIPERSONNEL MINES - Continued				
Mine, APERS, M26	Critical	1. Cotter pin improperly assembled	Visual	
		2. Arming latch fingers not seated under cam flange	Visual	
	Major	1. Sealing plug loose or missing	Visual/ manual	1.00
		2. Take up ring insecure	Visual/ manual	0.65
		3. Trip lever missing	Visual	0.65
		4. Arming instructions tag missing or instructions thereon incorrect or illegible	Visual	0.65
		5. Cover locking pin missing	Visual	1.00
		6. Spool assembly damaged	Visual	0.65
		7. Arming latch handle missing	Visual	0.65
		8. Marking missing or illegible	Visual	0.40
9. Arrow on cover ring not alined with letter S on body	Visual	1.00		
10. Spool retainer missing	Visual	0.65		
Mine, APERS: M86	Critical	1. Missing safety pin	Visual	
		2. Missing safety clip assembly	Visual	
	Major	1. Shorting bar broken or missing	Visual	0.65
		2. Shorting bar hook missing or broken	Visual	0.65
		3. Arming ring and strap damaged	Visual	0.65
		4. Triplines damaged or missing	Visual	0.65
		5. Crack(s) in mine body	Visual	0.65
6. Marking missing or illegible	Visual	0.40		
7. Missing, damaged, or incomplete seal of plastic bags	Visual	0.40		
Mine, APERS, Practice M8 with Fuze Mine Practice M10	Critical	None listed		
	Major	1. Missing components	Visual	0.25
2. Incorrect number of spotting charges or igniter charges		Visual	0.25	

Table 2-1. Classification of Material Defects - Continued

Item or component	Category	Defect	Method of Inspection	AQL
<b>SERVICE ANTIPERSONNEL MINES - Continued</b>				
Mine, Anti-personnel, M16A1 Inert	Major	1. Mine body cracked or dented	Visual	0.40
		2. Accessories and/or components missing or damaged	Visual	0.40
		3. Markings incorrect or illegible	Visual	0.40
Mine, APERS, Practice M35	Critical	None listed		
	Major	1. Arming latch missing	Visual	0.65
		2. Cover and arming latch assembly incorrectly postponed	Visual	0.65
		3. Arming instruction tag missing or damaged	Visual	0.65
		4. Instructions on instruction tag missing, illegible, or incorrect	Visual	0.65
		5. Spool retainer missing or incorrectly assembled	Visual	0.65
		6. Cam damaged (cracked or chipped)	Visual	0.65
		7. Trip lever missing from spool assembly	Visual	0.65
		8. Arming latch handle missing from spool assembly	Visual	0.65
		9. Set screws missing	Visual	0.65
		10. Paint color incorrect	Visual	0.65
		11. Replacement parts, tools, or materials missing or incomplete	Visual	0.65
Mine APERS: Practice M68	Critical	None listed		
	Major	1. Mine or accessory missing, damaged, or incorrectly packed	Visual	0.40
		2. Markings incorrect	Visual	0.40
<b>SERVICE ANTITANK MINES</b>				
Mine, AT, HE, Heavy M15 with Fuze, Mine, AT, M603	Critical	None Listed		
	Major	1. Heavy corrosion in fuze well	Visual	0.40
		2. Fuze well thread damaged	Visual	0.40
		3. Missing booster retainer in fuze well	Visual	0.40
		4. Components missing or damaged	Visual	0.40
		5. Body cracked or penetrated by rust	Visual	0.40
		6. Major corrosion	Visual	0.40
7. Secondary fuze well corrosion	Visual	0.40		

Table 2-1. Classification of Material Defects - Continued

Item or component	Category	Defect	Method of inspection	AQL
SERVICE ANTITANK MINES - Continued				
Fuze, Mine: M624	Critical	1. Boxed end assembly missing	Visual	
		2. Collar cracked	Visual	
		3. Cap assembly missing or improperly secured	Visual	
	Major	1. Fuze assembly damaged (dented, deformed, cracked, and/or punctured)	Visual	0.65
		2. Threads damaged or corroded	Visual	0.65
		3. Gasket missing or damaged	Visual	0.65
4. Delay element missing, damaged, or corroded		Visual	0.40	
		5. Tightening holes damaged, missing	Visual	0.65
		6. Tilt rod missing or damaged	Visual	0.65
Mine, AT, HE, NM, M19 with Fuze, Mine, M606	Critical	Indicator mark on fuze missing or incorrect	Visual	
	Major	1. Assembly cracked or split	Visual	0.65
		2. Carrying cord missing	Visual	0.65
		3. Booster pellet missing	Visual	0,40
		4. Fuze assembly missing or damaged	Visual	0.65
		5. Components missing	Visual	0.40
		6. Fuze assembled with detonator holder assembly in lieu of shipping plug	Visual	0.65
		7. Fuze not on safe	Visual	0.65
8. Housing gasket missing	Visual	0.65		
Mine, AT, Heavy M21 with Fuze, Mine Combination AT, M607	Critical	1. Any break in chamber for main charge	Visual	
		2. Pull ring assembly missing	Visual	
	Major	1. Shipping plug, charge cap, or closing plug turns when torque of 30 in.- lbs is applied in tightening direction	Visual/torque	0.65
		2. Charge cap is missing	Visual	0.65
		3. Fuze hole thread damaged	Visual	0.65
		4. Components missing	Visual	0.65
		5. Closure assembly turns when minimum torque of 15 in.- lbs is applied in tightening direction	Torque	
		6. Fuze assembly damaged (dented, deformed, cracked, or punctured)	Visual	0.65

Table 2-1. Classification of Material Defects - Continued

Item or component	Category	Defect	Method of inspection	AQL
SERVICE ANTITANK MINES - Continued				
Mine, AT, M24 with Fuze Rocket Base Detonating M404A1	Critical	1. Shorting plug missing (rocket)	Visual	
		2. Cable not twisted on form (rocket)	Visual	
		3. Safety pin band missing on fuze (rocket)	Visual	
	Major	1. Grounding clip not assembled	Visual	0.40
		2. Shorting clip removal notice missing or illegible	Visual	0.40
		3. Accessory missing, damaged, or insecurely assembled	Visual	0.65
Mine, AT, Heavy Practice M12A1 and M20 w/Fuze, Mine, AT, Practice M604	Major	None listed		
		1. Mine body cracked or dented	Visual	0.40
		2. Mine body excessively rusted or corroded with penetration through case	Visual	0.40
		3. Damaged threads and/or heavy rust in fuze well	Visual	0.40
Mine, Anti-tank, Training: M80 w/Fuze M606, Inert	Major	4. Accessories or components missing or damaged	Visual	0.40
		1. Mine body cracked or dented	Visual	0.40
		2. Accessories and/or components missing or damaged	Visual	0.40
		3. Marking incorrect	Visual	0.40

### Section III. INSPECTION METHODS

#### 2-5. General

a. Visual inspection involves taking note of listed defects and any other abnormalities. For example, sealed packages are usually subjected only to visual inspection.

b. Manual inspection is accomplished by moving the hand over a specified area of the

item to determine presence of listed defect(s) (e.g. incorrect or loose part).

c. Gage inspection involves checking an item with a measuring instrument or a standard mating piece to determine whether size is acceptable in certain critical areas. Defects are derived from either predetermined standards or on a go-no-go basis.

## SECTION IV. DISPOSITION OF LOTS

### 2-6. General.

a. Lots in which critical nonfunctioning defects are found shall be reported to the appropriate commodity command by the most expeditious means, giving the nomenclature, lot or serial number of the item, the defect encountered and the number of samples examined. However, critical defects found during in-process inspection or final acceptance inspection and caused by the maintenance process need not be reported. Each lot of such material shall be inspected and screened 100 percent. If a critical functioning defect occurs, save remaining pieces and components; suspend the lot from local issue; and use and submit a malfunction report as prescribed in AR 75-1. A report shall be made

to the appropriate commodity command by the most expeditious means. Disposition instructions will be furnished by the U.S. Army Armament Research, Development and Engineering Center (ARDEC).

b. A lot of materiel is acceptable for issue and use if it meets the criteria in table 2-1.

c. Mine lots which fail to meet prescribed standards shall be reported for disposition in accordance with DA Pam 750-8. State whether your organization is capable of reworking/demilitarizing the item based upon your capability and workload.

**THIS PAGE INTENTIONALLY LEFT BLANK**

## CHAPTER 3 DIRECT SUPPORT MAINTENANCE

### SECTION I. INTRODUCTION

#### 3-1. General.

a. Direct support (DS) maintenance operations are restricted to the procedures in this manual and in TM 9-1345-203-12, as indicated in the Maintenance Allocation Chart (MAC). The DS personnel perform maintenance functions of lower maintenance levels when required or directed by the appropriate commander. The DS units are also responsible for receiving and storing packaging materials salvaged from expended ammunition and or providing technical assistance to operator and organizational units.

b. In general, DS maintenance operations include, but are not limited to, the following:

- (1) Unpacking and repacking.
- (2) Inspection and testing.
- (3) Cleaning and preservation of individual items and packaging materials.
- (4) Removal of light rust and corrosion.
- (5) Repair and replacement of packaging materials.
- (6) Painting and marking.

c. Before beginning maintenance operations, a line layout and SOP are required. Guidelines for setting up a line and writing the SOP are contained in TM 9-1300-250.

d. Packing materials and expendable supplies which are locally stocked are listed in appendixes B and C, respectively. Recoverable items such as packing material should be returned for future use if they are serviceable.

#### 3-2. Direct Support Maintenance.

a. Direct support maintenance is performed under the following conditions:

- (1) Upon receipt of unserviceable ammunition.
- (2) When maintenance is authorized to correct deficiencies in suspended ammunition lots.
- (3) When operator and/or organizational units request on-site assistance.
- (4) When inspection of on-hand stocks reveals the need.

b. Unpacking and repacking procedures are given in TM 9-1345-203-12, chapter 4. Premaintenance, in-process, and final acceptance inspection are defined in chapter 2.

c. Deleted.

### SECTION II. CLEANING

#### 3-3. General.

Ground all mines containing explosives.

**WARNING**

**USE ONLY ELECTRICAL EQUIPMENT WITH NATIONAL ELECTRICAL CODE RATING OF CLASS I FOR FLAMMABLE VAPOR; CLASS II FOR EXPLOSIVE DUSTS (INCLUDING AMMUNITION) OR WITH DUAL RATING IF BOTH VAPOR AND DUSTS ARE PRESENT.**

a. Tools and Equipment.

- (1) Waste can for flammable waste.
- (2) Nonferrous brush.
- (3) Plunger-type safety can.

b. Expendable Supplies.

- (1) Alcohol.
- (2) Acetone.
- (3) Corrosion-removing compound.
- (4) Rags.
- (5) Sandpaper, abrasive.

**3-4. Procedure.**

**WARNING**

**STORE RAGS IN NONCOMBUSTIBLE SELF-CLOSING CONTAINERS. PLACE WASTE OR USED RAGS IN WATER-FILLED CONTAINERS. ASSURE THAT AREAS IN WHICH SOLVENTS ARE USED ARE WELL VENTILATED.**

- a. Remove dirt, mud, and other foreign material using rags or brushes. Remove grease using rags dampened with alcohol or acetone. Clean fuze well and threads with clean, dry rags.

- b. Remove flaked, chipped, blistered, or peeling paint using nonferrous brush.
- c. Clean only to degree necessary to remove rust using nonferrous brush or sandpaper.
- d. Clean corrosion from aluminum or copper-based metals by brushing with nonferrous brush. Remove residue with rags or corrosion-removing compound.
- e. Inspect cleaned item for cracks or other damage or deterioration.
- f. Allow solvent-cleaned surfaces to dry thoroughly before painting.

### SECTION III. REPAIR

**3-5. Packaging Materials.**

a. *General.* Detailed procedures for authorized repair of most packaging materials are given in TM 9-1345-203-12, chapter 4. Procedures authorized at DS level are presented below.

b. *Wirebound Box Loops.*

(1) Tools and equipment.

- (a) Hammer.
- (b) Tin snips.
- (c) Wire cutter.

(2) *Expendable Supplies.*

- (a) Repair loop, 13 gauge wire.
- (b) Wire.

**3-6. Procedure.**

This procedure (fig. 3-1) is preferred if appropriate wire cutter and repair loops are available. If these cannot be obtained, follow alternate repair procedure (para 3-7).

**NOTE**

In connection with step references, see figure 3-1.

- a. Remove broken loop by cutting wire (step 1).
- b. Cut first staple and release wire (step 2).
- c. Slide one end of repair loop onto binding wire (step 3).
- d. Place notch of wire cutter 1/4-inch to 3/8-inch from end of wire; bend wire into half circle (step 4).
- e. Insert bent end of wire into repair loop coil and slide loop up (step 5).
- f. Lock repair loop in place by further bending wire end with notch of wire cutter (step 6).

**3-7. Alternate Procedure.**

Proceed as follows to repair broken wire loop on wirebound box if both legs of broken loop are securely fastened to box:

- a. Cut off broken loop even with top of edge of box.
- b. Using pliers, bend remaining wire legs back 1/2 inch, forming half circles.
- c. Cut 6-inch length of wire to replace broken loop.
- d. Bend repair wire in half to form "U". Then bend about 1/2 inch of each leg outward about 150 degrees.
- e. Hook bent legs of repair wire into half circles of box wires.



- f. Twist ends of repair wire around ends of box wires.
- g. Place box on hard surface or place steel bar under repair area.

- h. Secure repair by hammering each half circle on box wire where it is connected to repair wire.

**Section IV. TOUCHUP, PAINTING, AND MARKING**

**3-8. Touchup**

a. *General.* Clean item(s), following procedure in paragraph 4-4.

b. *Tools and Equipment.*

- (1) Waste can for flammable waste.
- (2) Paint brush.
- (3) Plunger-type safety can.
- (4) Respirator.
- (5) Small brush.
- (6) Paint sprayer.

c. *Expendable supplies.*

- (1) Alcohol, denatured.
- (2) Clean rags.
- (3) Disposable plastic gloves.
- (4) Enamel of appropriate color.
- (5) Ink, marking stencil.
- (6) Masking tape.
- (7) Primer, zinc chromate.
- (8) Sandpaper, abrasive.

d. *Procedure.*

- (1) Record all marking data. Should these be removed or obliterated during processing, re-mark item(s).
- (2) Lightly buff cleaned, bare, metal surface and surrounding paint with fine sandpaper.
- (3) Wipe surface of item with clean rag

dampened with alcohol to remove loosened particles.

- (4) Cover legible markings and threaded surfaces with masking tape.
- (5) Using brush, cover bare metal with thin coat of zinc chromate primer.
- (6) Air-dry 30 to 60 minutes or until surface is no longer tacky.
- (7) Cover primed area evenly with one thin coat of enamel in appropriate color.
- (8) Air-dry 30 to 60 minutes or until surface is no longer tacky.

**WARNING**

**WEAR RESPIRATOR DURING SPRAY PAINT OPERATIONS.**

- (9) If spray gun or spray can is used, cover primed area evenly with two very thin coats of enamel in appropriate color, allowing first coat to dry thoroughly before applying second coat.
- (10) Remove masking tape.
- (11) Restencil or, using small paint brush, touch up markings.

**3-9. Painting**

a. *General.* Clean item(s) following procedures in paragraph 3-4. Repaint mines, components, and metal containers which have been cleaned extensively or to degree that large areas of metal surface are bare.

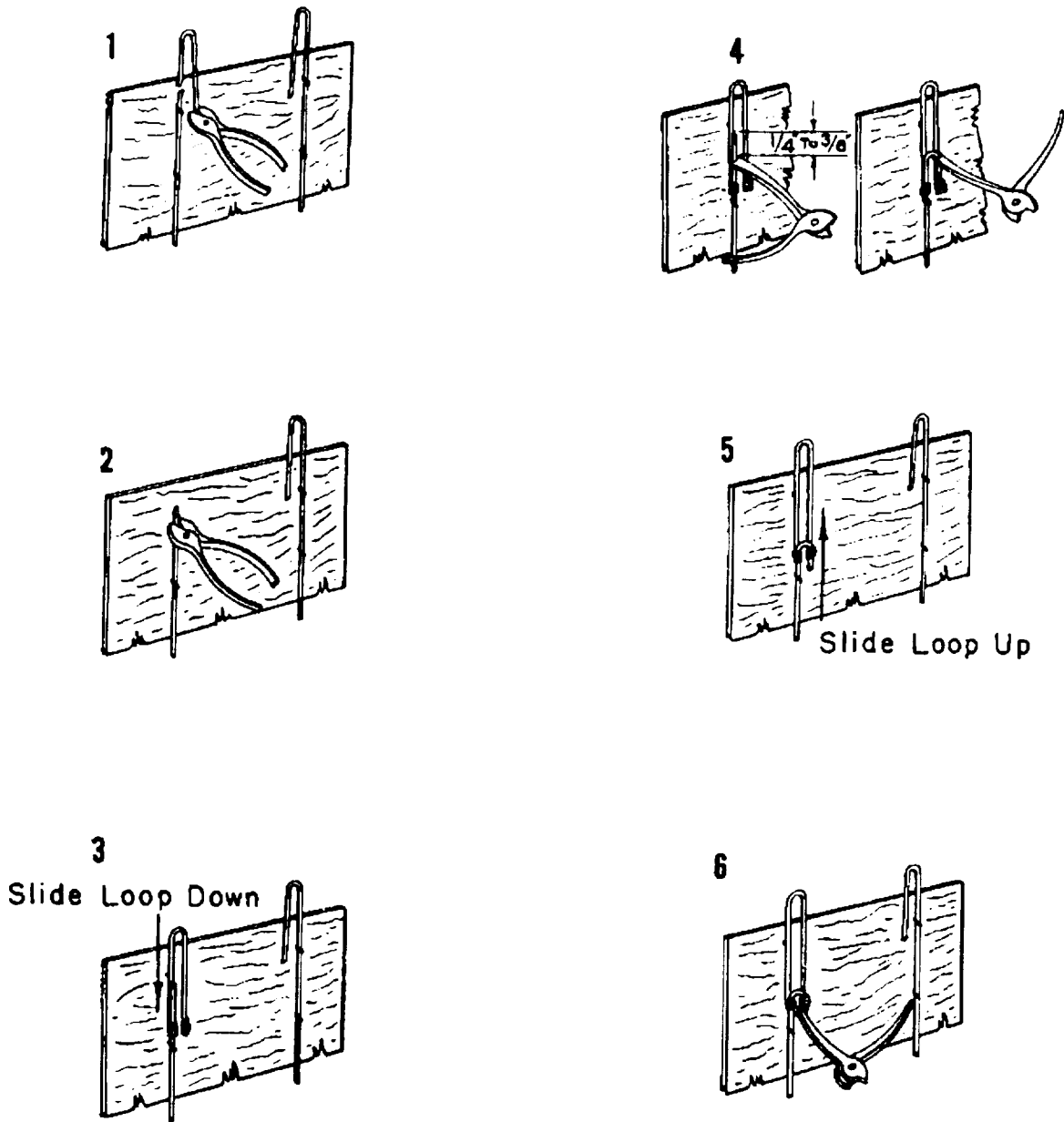

AR 100333

Figure 3-1. Repairing loops on wirebound box

**NOTE**

Temperature of both paint and item to be painted must be between +50°F and + 100°F for paint to adhere and dry properly. Ambient (surrounding air) temperature must be above + 50°F.

- (1) Tools and equipment.
  - (a) Waste can for flammable waste.
  - (b) Improvised setups (prefabricated).
  - (c) Paint brush.
  - (d) Paint sprayer.
  - (e) Plunger-type safety can.
  - (f) Respirator.
- (2) Expendable supplies.
  - (a) Alcohol, denatured.
  - (b) Clean rags.
  - (c) Disposable plastic gloves.
  - (d) Enamel of appropriate color.
  - (e) Masking tape.
  - (f) Primer, zinc chromate.
  - (g) Sandpaper, abrasive.
- (3) Procedure. Remove as much old paint as possible with cleaning materials furnished. Follow procedures in paragraph 3-8d (1) through (3). Cover any parts (threads, etc.) not to be painted with masking tape. Use improvised setups to suspend or cradle item to be painted.

**WARNING**

**WEAR RESPIRATOR DURING SPRAY PAINT OPERATIONS.**

Proceed as indicated below:

- (a) Using spray gun, spot prime any bare metal with thin coat of zinc chromate primer. Do

not prime over painted surface. Assure that all bare metal is primed.

- (b) Air-dry 30 to 60 minutes or until surface is no longer tacky.
- (c) Using spray gun, cover item surface evenly with one thin coat of enamel in appropriate color.

**NOTE**

Assure that paint covers old, unwanted markings.

- (d) Air-dry 30 to 60 minutes or until surface is no longer tacky.
  - (e) Touch up, as required.
  - (f) Remove masking tape.
  - (g) Restore markings following procedures in paragraph 3-11.
- b. Wooden Packing Box. Ordinarily wooden boxes are painted to obliterate old markings.

- (1) Tools and equipment.
  - (a) Waste can for flammable waste.
  - (b) Paint brush.
  - (c) Paint sprayer.
  - (d) Plunger-type safety can.
  - (e) Respirator.
- (2) Expendable supplies.
  - (a) Enamel, olive drab.
  - (b) Obliterating lacquer.
  - (c) Masking tape.
  - (d) Primer, zinc chromate.
- (3) Procedure.
  - (a) Assure that box is clean and dry.
  - (b) Cover markings to be retained with masking tape.

**WARNING**

**WEAR RESPIRATOR DURING  
SPRAY PAINT OPERATIONS.**

- (c) Using paint brush or spray gun, cover unwanted markings with marking obliterating lacquer or olive drab enamel; assure complete coverage. Repaint as required.
- (d) Air-dry 30 to 60 minutes or until surface is no longer tacky.
- (e) Remove masking tape.
- (f) Mark as required following procedures in paragraph 3-11.

*c. Fiberboard Container.*

- (1) Tools and equipment
  - (a) Waste can for flammable waste.
  - (b) Paint brush.
  - (c) Paint sprayer.
  - (d) Plunger-type safety can.
  - (e) Respirator.
- (2) *Expendable supplies.*
  - (a) Coating compound.
  - (b) Enamel, black.
  - (c) Kraft paper.
  - (d) Masking tape.
  - (e) Primer, zinc chromate.
  - (f) Rags.

(3) *Procedure.*

- (a) Inspect containers, reject those with holes or with unre-movable rust spots.
- (b) Clean container and cap following procedures in section II.
- (c) Using kraft paper and mask-ing tape, cover metal ends and unpainted inner surface.

**WARNING**

**WEAR RESPIRATOR DURING  
SPRAY PAINT OPERATIONS.**

- (d) Using brush or spray gun, cover outer surface of con-tainer and cap with coating compound; assure complete cov-erage. Repaint as required.
- (e) Air-dry 30 to 60 minutes or until surface is no longer tacky
- (f) Remove masking tape and kraft paper from cap and inner surface and, with these, cover outer surface.
- (g) Using spray gun, cover metal with zinc chromate primer.
- (h) Air-dry 30 to 60 minutes or until surface is no longer tacky.
- (i) Using paint brush or spray gun, cover metal ends with black enamel; assure complete coverage. Repaint as required.
- (j) Air-dry 30 to 60 minutes or until surface is no longer tacky.
- (k) Remove masking tape and kraft paper.
- (l) Mark as required, following procedures in paragraph 3-11.

**3-10. Color Coding of Boxes With Light Loads**

a. *General.* The following procedure applies to less-than-full boxes which are to be returned to a storage area or transported to a new location,

b. *Tools and Equipment.*

- (1) Waste can for flammable waste.
- (2) Paint brush.
- (3) Plunger-type safety can.
- (4) Respirator.
- (5) Small brush.
- (6) Paint sprayer.

c. *Expendable Supplies.*

- (1) Disposable plastic gloves.
- (2) Masking tape.
- (3) Orange enamel or lacquer.

d. *Procedure.*

- (1) Check contents with markings on box to verify that nomenclature and lot number are correct.
- (2) Make diagram of markings on box and carefully record all marking data except quantity number.
- (3) Cover original markings except quantity figure with masking tape.



**WEAR RESPIRATOR DURING SPRAY PAINT OPERATIONS.**

- (4) Using paint brush or spry gun, cover entire outer surface of box with orange enamel or lacquer.
- (5) Air-dry 30 to 60 minutes or until surface is no longer tacky.
- (6) Remove masking tape.
- (7) Re-mark as required following procedures in paragraph 3-11.
- (8) Count items in box; mark quantity in place of original number and stencil LIGHT BOX on each side of box.

**3-11. Marking.**

- a. *General.* Consistent with available space, 1/8-inch, 1/4-inch, 1/2-inch, 3/4-inch and 1-inch capital letters are used for marking items and packaging. Lettering size on current stocks is not changed, however, unless rework/renovation is performed required remarking. In any case, marking is not applied until inappropriate marks have been obliterated.
- b. *Tools and Equipment.*
  - (1) Disposable flammable-waste can.
  - (2) Fountain stencil brush.

- (3) Masking tape.
- (4) Plunger-type safety can.,
- (5) Rubber type set.
- (6) Worktable.

c. *Expendable Supplies.*

- (1) Clean rags.
- (2) Disposable plastic gloves.
- (3) Masking tape.
- (4) Solvent.
- (5) Stencil board.
- (6) Stencil ink.

d. *Procedure for Packing Materials.*

- (1) Apply markings in color which contrasts with color of packaging material unless otherwise specified.
- (2) See ammunition data card for specific markings or copy from old package.
- (3) Apply markings by either rubber-type, or stencil method outlined in 3-11e below.
- (4) Mark inner packs with information usually found on item. If items have no inner packs, stencil information on cardboard and include in repacked box.
- (5) Refer to appendix D for location and size of markings for fiber container, metal container, and wooden boxes.
- (6) Clean all marking equipment as often as necessary and at end of each shift or termination of job, whichever comes first.

e. *Procedure of Mines and Related Items.* For specific markings, check ammunition data card or another item for same lot. Apply markings by using rubber type or stencil as follows:

- (1) Rubber type method.
  - (a) Set type for required information in holder.
  - (b) Apply small amount of ink to ink plate.

- (c) Move roller back and forth on plate to distribute ink evenly.
  - (d) Mover roller lightly across face of rubber type to apply light film of ink to type.
  - (e) Carefully roll item to be marked across rubber type.
  - (f) Check markings; assure they are correct, neat, and legible.
- (2) Stencil Method.
- (a) Make stencil covering required information.
  - (b) Apply dab of ink to ink plate.
  - (c) Rub brush in ink to apply ink to bristles.
  - (d) Position stencil cutout over area to be marked.
  - (e) While holding stencil firmly against item (using masking tape, if required), rub bristles of brush over stencil cutout to apply marking to item.

**NOTE**

A spray gun or can with paint of proper color may be used instead.

- (f) Carefully remove stencil and/or masking tape.
- (g) Check markings; assure they are correct, neat, and legible.

f. *Painting and Marking Data.*

(1) General. Land mines are identified by nomenclature, lot number, model, painting, and markings. Although, basically, ammunition is painted to retard rusting, color is used for the following purposes:

- (a) To identify practice and training items.
- (b) To indicate type of filler (e.g., high or low explosive).
- (c) To code primary role(s) of the ammunition.

**NOTE**

Practice ammunition, which conforms to the configuration of the service item, may be a modification or a model designed specifically for practice. It may contain explosives and is used during training exercises.

(2) Color coding. Color coding, in general, conforms with requirements in applicable ammunition specifications and drawings. When color coding is used on packaging and packing to identify ammunition contents, the colors specified in MIL-STD-709 apply. Colors used for camouflage have no color coding significance.

(3) Application of color coding. Color coding is applied as the normal protective coating (overall body color) or as circumferential bands, in addition to identification markings. A combination of applications typically indicates the main identification details and special features (e.g., type of filler). BLACK and WHITE, when used for lettering, have no color coding significance. Formally, HE mines and related items were painted olive drab. Markings were in yellow. Some items also had yellow stripes or bands, closing plugs being painted yellow. Practice mines were painted blue and marked in white. Inert mines were painted black. Under the new system, a yellow band identifies HE ammunition; the body is painted olive drab and markings are white for the main identification details. Practice mines containing low explosives are painted blue with a brown band and markings are in white. Inert mines are painted blue or gold. Markings, including the INERT, are in white.

(4) Materials. Color coding materials (e.g., paints, enamels, lacquers, marking inks, decals, strippable tapes) differ as required by the applicable ammunition drawings and specifications. Colors specified, however, in all cases match those of the corresponding numbers in FED STD No. 595B, except that the first digit of the number may be changed in accordance with the ammunition requirements for a gloss, semi-gloss, or a lusterless finish.

(5) Data marking. Nomenclature. Nomenclature, lot number, month and year loaded (including loader's initials and symbol) may be in the same color as the other markings, in black or white, or by stamping, as required by the ammunition data card or another item from same lot. Refer to appendix D for typical markings.

## CHAPTER 4 GENERAL SUPPORT MAINTENANCE

### SECTION I. INTRODUCTION

#### 4-1. General.

General support (GS) maintenance includes those maintenance operations which are beyond the scope of tools, equipment, personnel, or supplies normally available to lower maintenance levels. Although accomplished under the same conditions as direct support (DS) maintenance, GS maintenance involves greater quantities of ammunitions.

maintenance functions of lower maintenance levels when required or directed by the appropriate commander.

b. Repair parts, packing materials and expendable supplies (appendixes B and C) required by GS units will be locally stocked. The GS units, as in the case of DS units, are also responsible for receiving and storing packaging materials salvaged from expended ammunition and for providing technical assistance to operator and organizational units.

#### 4-2. General Support Maintenance.

a. General support maintenance operations are restricted to the procedures in this manual and in TM 9-1345-203-12, as indicated in the MAC. The GS personnel also perform

c. Before beginning maintenance operations, a line layout and SOP are required. Guidelines for organizing the line and writing the SOP are contained in TM 9-1300-250.

### SECTION II. REPAIR PARTS, SPECIAL TOOLS AND EQUIPMENT AND EXPENDABLE SUPPLIES

#### 4-3. Maintenance Repair Parts.

Repair parts are listed in TM 9-1345-203-12, appendix B, section II.

#### 4-5. Special Tools and Equipment.

Special tools or equipment required for GS maintenance are listed in TM 9-1345-203-12, appendix B, section III.

#### 4-4. Tools and Equipment.

Standard and commonly used tools and equipment having general application to mines are authorized for issue by TA and TOE.

#### 4-6. Expendable Supplies.

Supplies and materials required for maintenance support of the equipment covered herein are authorized to be requisitioned by CTA 50-970. Expendables include paints.

### SECTION III. PROCEDURES

#### 4-7. Cleaning.

See chapter 3, section III.

#### 4-8. Repair.

See chapter 3, section III.

#### 4-9. Touchup, Painting, and Marking.

See chapter 3, section IV.

#### 4-10. Barrier Bags.

##### a. *Tools and Equipment.*

- (1) Heat sealing machine.
- (2) Scissors or knife.

##### b. *Expendable Supplies.*

- (1) Barrier material.
- (2) Tape PPP-T-60.

c. Procedure.

**NOTE**

This procedure is authorized at GS level only. Although basically a repacking procedure, the following is normally undertaken on a repair basis.

- (1) Receive bag from unpacking operation. Assure that reseal items have been completely inspected and found serviceable.
- (2) Inspect barrier bag and accept or reject as warranted.

**NOTE**

Acceptable bags are intact except for opening slit and can be resealed after contents are reinserted.

- (3) Trim open end of bag if ragged.
- (4) If bag corners are delaminated but bag is otherwise intact and can be sealed, use heat sealing machine to relaminate corners.
- (5) Set rejects aside for later disposal.
- (6) If markings are obliterated on otherwise undamaged bags, re-mark in this connection, see paragraph 3-11.
- (7) If new barrier bag is required, proceed according to replacement procedures in either (8) or (9) below.
- (8) If replacement involves use of two sheets of barrier material, proceed as follows:
  - (a) Cut two sheets equal to outside dimensions of original bag.
  - (b) Place two cut sheets together, plastic-coated surfaces together; aline edges.
  - (c) Seal bottom and two longest edges using heat sealing machine.

- (9) If replacement involves use of one sheet of barrier material, proceed as follows:
  - (a) Cut one sheet equal to outside width and twice outside length of original bag.
  - (b) Fold length dimension of sheet in half with plastic-coated surfaces together.
  - (c) Seal bottom and two longest edges using heat sealing machine.
- (10) Leave shortest edge of bag unsealed for bag opening.
- (11) Assure that heat seals are at least 1/2-inch wide.
- (12) Assure that item to be repacked and packing materials are clean and dry.
- (13) Place item(s) into original inner pack in original manner using all padding materials. Use extra padding materials to fill voids and to prevent item from moving. Tape inner pack to secure it, if necessary.
- (14) Place inner pads in barrier bag in original orientation using creases, etc., as a guide.
- (15) Heat-seal bag opening except for approximately 1-inch width from end.
- (16) Flatten bag around inner pack; press sides of open end of bag together to force out excess air. Compress open corners of bag with fingers to prevent entrance of air; seal remaining (unsealed) portion of bag opening. Seal full width of sealing bar.
- (17) Assure that heat seal is a least 1/2-inch wide and that seal is complete.
- (18) Fold sealed end in original manner as indicated by impressions in bag.
- (19) Mark in accordance with procedures in paragraph 3-11.



## APPENDIX A REFERENCES

### A.1 SCOPE.

This appendix lists all Army regulations, forms, pamphlets, supply bulletins, supply catalogs, technical manuals, and miscellaneous publications referenced in this manual. The publication index (DA Pam 25-30) should be consulted frequently for latest changes or revisions of references given in this appendix and for new publications relating to the material covered in this manual.

### A.2 ARMY REGULATIONS.

Malfunctions Involving Ammunition and Explosives .....	AR 75-1
Accident Reporting and Records.....	AR 385-40
U.S Army Explosives Safety Program.....	AR 385-64
U.S. Army Munitions Reporting Systems.....	AR 700-19
Ammunition Stockpile Reliability Program (ASRP) .....	AR 702-6
Quality Assurance Specialist (Ammunition Surveillance).....	AR 702-12
Storage and Supply Activity Operations .....	AR 740-1

### A.3 FORMS.

U.S. Army Accident Report .....	DA Form 285
Recommended Changes to Publications and Blank Forms.....	DA Form 2028

### A.4 PAMPHLETS.

Consolidated Index of Army Publications and Blank Forms.....	DA Pam 25-30
Ammunition and Explosives Safety Standards .....	DA Pam 385-64
The Army Maintenance Management System (TAMMS) Users Manual.....	DA Pam 750-8

### A.5 SUPPLY BULLETINS.

Inspection of Supplies and Equipment Ammunition Surveillance Procedures.....	SB 742-1
--	----------

### A.6 SUPPLY CATALOGS.

Consolidated Publication of Components List.....	SC 9999-01-SKO
--	----------------

### A.7 TECHNICAL MANUALS.

Ammunition Maintenance.....	TM 9-1300-250
Operator's and Organizational Maintenance Manual for Land Mines.....	TM 9-1345-203-12

**A.8 MISCELLANEOUS PUBLICATIONS.**

Army Medical Department Expendable/Durable Items.....	CTA 8-100
Expendable/Durable Items (Except: Medical Class V, Repair Parts, and Heraldic Items).....	CTA 50-970
Colors Used in Government Procurement .....	FED STD No. 595
Ammunition Color Coding.....	MIL-STD-709
Ammunition Lot Numbering and Ammunition Data Card .....	MIL-STD-1168

**APPENDIX B  
EXPENDABLE AND DURABLE ITEMS LIST**

**Section I. INTRODUCTION**

**B-1. Scope**

This appendix lists expendable and durable items that you will need to operate and maintain the Land Mines. This listing is for information only and is not authority to requisition the listed items. These items are authorized to you by CTA 50-970, Expendable/Durable Items (except medical, class V repair parts, and heraldic items), or CTA 8-100, Army Medical Department Expendable/Durable Items.

**B-2. Explanation of Columns**

a. *Column 1.* Item number. This number is assigned to the entry in the listing and is referenced in the narrative instructions to identify

the item (e.g. "Use cleaning compound, item 5, Appendix D").

b. *Column 2.* Level. This column identifies the lowest level of maintenance that requires the item.

c. *Column 3.* National stock number. This is the national stock number assigned to the item which you can use to requisition it.

d. *Column 4.* Item name, description, Commercial and Government Entity 'Code (CAGEC), and part number. This provides the other information you need to identify the item.

e. *Column 5.* Unit of measure. This code shows the physical measurement or count of an item, such as gallon, dozen, gross, etc.

**Section II. EXPENDABLE/DURABLE SUPPLIES AND REQUIREMENTS LIST**

(1) Item No.	(2) Level	(3) National Stock Number	(4) Item Name, Description CAGEC, Part Number	(5) Unit of Measure
1	O	6810-00-184-4796	Acetone, technical (81348) O-A-51	GL
2	O	6810-00-543-7415	Alcohol, Denatured: grade III (81348) OE760	GL
3	O	8135-00-282-0565	Barrier Material: Water- proofed, Flexible 200-yd roll, 36 in. wide, class I (19203) 801560	YD
4	O	8520-00-782-3509	Hand Cleaner: type I, class 2 cream, nonantimicro- bial, grade A (10266) DD10	LB
5	O	8030-00-664-7105	Coating Compound, Bi- tuminous: solvent type, type I (low solids) (81349) MIL-C-450	GL

(1) Item No.	(2) Level	(3) National Stock Number	(4) Item Name, Description CAGEC, Part Number	(5) Unit of Measure Measure
6	O	8030-00-290-5141	Coating Compound, Bi- tuminous: solvent type, type II (medium solids) (81349) MIL-C-450	GL
7	O	6850-00-174-9672	Corrosion Removing Com- pound: wipe-off type, type II, bottle (81349) MIL10578	GL
8	O	7930-00-249-8036	Detergent, General Purpose: painted surface, powdered (58536) A-A-1376	LB
9	O	8010-00-910-8154	Enamels:  Black, No. 37038 (81348) TT-E-516	OZ
10	O	8010-00-067-5436	Colorless (81348) TT-E-00488	PT
11	O	8010-00-848-9272	Olive Drab, No. 34087 (81348) TT-E-516	PT
12	O	8010-00-851-5525	Yellow, No. 23538 (81349) MIL-E-16663	PT
13	O	8010-00-297-2122	Black, No. 37038 (96906) MS35527-2	GL
14	O	8010-00-297-2119	Medium Blue, No. 35109 (96906) MS35527-3	GL
15	O	8010-00-828-3193	Light Green, No. 34558 (81348) TT-E-516	GL
16	O	8010-00-297-2116	Olive Drab, No. 34087 (96906) MS35527-8	GL
17	O	8010-00-088-0096	Orange, (Vivid) No. 32246 (81348) TT-E-515	QT
18	O	8010-00-297-0563	Orange, (Vivid) No. 35524-13 (96906) MS35524-13	GL
18a	O	8010-01-160-6742	Green, Polyurethane 383 CARC 4 Gal Kit (81349) MIL-C-46168	GL

(1) Item No.	(2) Level	(3) National Stock Number	(4) Item Name, Description CAGEC, Part Number	(5) Unit of Measure Measure
19	O	8010-01-162-5578	Green, Polyurethane 383 CARC 1 Gal Kit (81349) MIL-C-46168	GL
20	O	8010-00-297-2112	Yellow, No. 33538 (96906) MS35527-12	GL
21	O	8010-00-297-2111	White, No. 37875 (81348) TT-E-515	GL
22	O	5315-00-597-9766	Fastener, Corrugated, Wood Joint: saw edge 1/2 in. deep (58536) A-A-1957	HD
23	O	8415-00-682-6786	Gloves, Disposable: plastic (96717) Pinkies	PR
24	O	7510-00-161-0811	Ink, Marking Stencil: black (58536) A-A-208	GL
25	O	7510-00-161-0815	Ink, Marking Stencil: white (58536) A-A-208	GL
26	O	7510-00-161-0816	Ink, Marking Stencil: yellow (58536) A-A-208	GL
27	O	8135-00-160-7757	Paper, Kraft: grade B, No. 2, 9-in. roll dia, 24 in. w, 40 lb (58536) A-A-203	FT
28	O	8010-00-527-3196	Lacquer: lusterless, sand, No. 30277 f/obliterating stencil markings (81348) TT-C-2114	GL
29	O	8010-00-161-7392	Lacquer: lusterless, sand, No. 30277 f/obliterating stencil markings (81348) TT-C-2114	GL
30	O	8010-00-584-3148	Lacquer: orange, No. 12197 (58536) A-A-665	PT
31	O	9150-00-231-6689	Lubricating Oil, General Purpose: (81348) VVL800	QT

(1) Item No.	(2) Level	(3) National Stock Number	(4) Item Name, Description CAGEC, Part Number	(5) Unit of Measure Measure
32	O	7520-00-973-1059	Marker, Tube Type: black (81348) GG-M-00114	DZ
33	O	7520-00-973-1062	Marker, Tube Type: red (81348) GG-M-00114	DZ
34	O	7520-00-079-0288	Marker, Tube Type: yellow (81348) GG-M-00116	DZ
35	O	5315-00-889-2743	Nail Box, General Purpose: style 4, type II, 4d, 1 1/2 in. (81348) FF-N-105	LB
36	O	5315-00-889-2744	Nail, Box, General Purpose: style 4, type II, 6d, 2 in. (81348) FF-N-105	LB
37	O	8010-00-161-7339	Primer, Coating: zinc chromate (71191) P-759-66	GL
38	O	7920-00-205-1711	Rag, Wiping: cotton, un- bleached, mixture (58536) A-A-2522	LB
39	O	5330-00-729-5103	Rubber, Sheet, Solid: rect, 1/8 thk, 36 w, 36 lg (58536) A-A-1719	EA
40	O	8135-00-239-5291	Seal, Strapping: for 5/8-in. steel strapping (81346) ASTM D 3953-87	BX
41	O	8135-00-239-5294	Seal, Strapping: for 4 1/4-in. steel strapping (81346) ASTM D 3953-87	BX
42	O	8030-00-245-7032	Sealing Compound: cement, pettman, paste, type A (81350) JANC99	GL
43	O	9310-00-240-4737	Stencilboard: oiled, type II, grade III, 18 1/2-in. x 18 1/2-in. (81348) UU-S-625	SH
44	O	8135-00-281-4071	Strapping, Steel: 5/8-in. w, 0.020 in. thk (81346) ASTM D 3953-87	LB

(1) Item No.	(2) Level	(3) National Stock Number	(4) Item Name, Description CAGEC, Part Number	(5) Unit of Measure Measure
45	O	7510-00-266-6711	Tape, Pressure Sensitive Adhesive: (masking) opaque, 3/4 in. w, 3 in. id, 60 yd lg, type I (26066) 232 3/4 in.	YD
46	O	7510-00-266-6712	Tape, Pressure Sensitive Adhesive: (masking) opaque, 1 in. w, 3 in. id, 60 yd lg, type I (19203) 8783476	YD
47	O	7510-00-266-6710	Tape, Pressure Sensitive Adhesive: (masking) opaque, 2 in. w, 3 in. id, 60 yd lg, type I (18876) 802563	YD
48	O	8135-00-266-6715	Tape, Pressure Sensitive Adhesive: 2 in. (58536) A-A-1830	YD
49	O	8010-00-242-2089	Thinner, Paint, Products: Mineral Spirits, grade I (81348) TT-T-291	GL
50	O	8010-00-160-5794	Thinner, Paint Products: Synthetic Resin Enamel (81348) TT-T-306	GL
52	O	5350-00-242-4405	Wool, Metallic: steel, 1 lb (58536) A-A-1043	LB

**THIS PAGE INTENTIONALLY LEFT BLANK**



**APPENDIX C**  
**MARKING INFORMATION FOR LAND MINES**

---

Figure No.	Title
C-1	Typical Marking Diagram for Fiber Containers.
C-2	Typical Marking Diagram for Metal Containers.
C-3	Typical Marking Diagram for Wooden Boxes.
C-4	Typical Markings for Service APERS Mines.
C-5	Typical Markings for Practice APERS Mines.
C-6	Typical Markings for Service AT Mines.
C-7	Typical Markings for Practice AT Mines.
C-8	Typical Markings for Fiber Containers.
C-9	Typical Markings for Metal Containers.
C-10	Typical Markings for Wooden Boxes.
C-11	Typical Markings for APERS Mines M86.
C-12	Typical Markings for Shipping & Storage Container PA19.

**NOTE**

Marking systems shown in this manual are those which have been used prior to issue of latest marking instructions. For latest current Lot Marking System, refer to MIL-STD-1168A, dated 28 February 1975, Ammunition Lot Numbering.

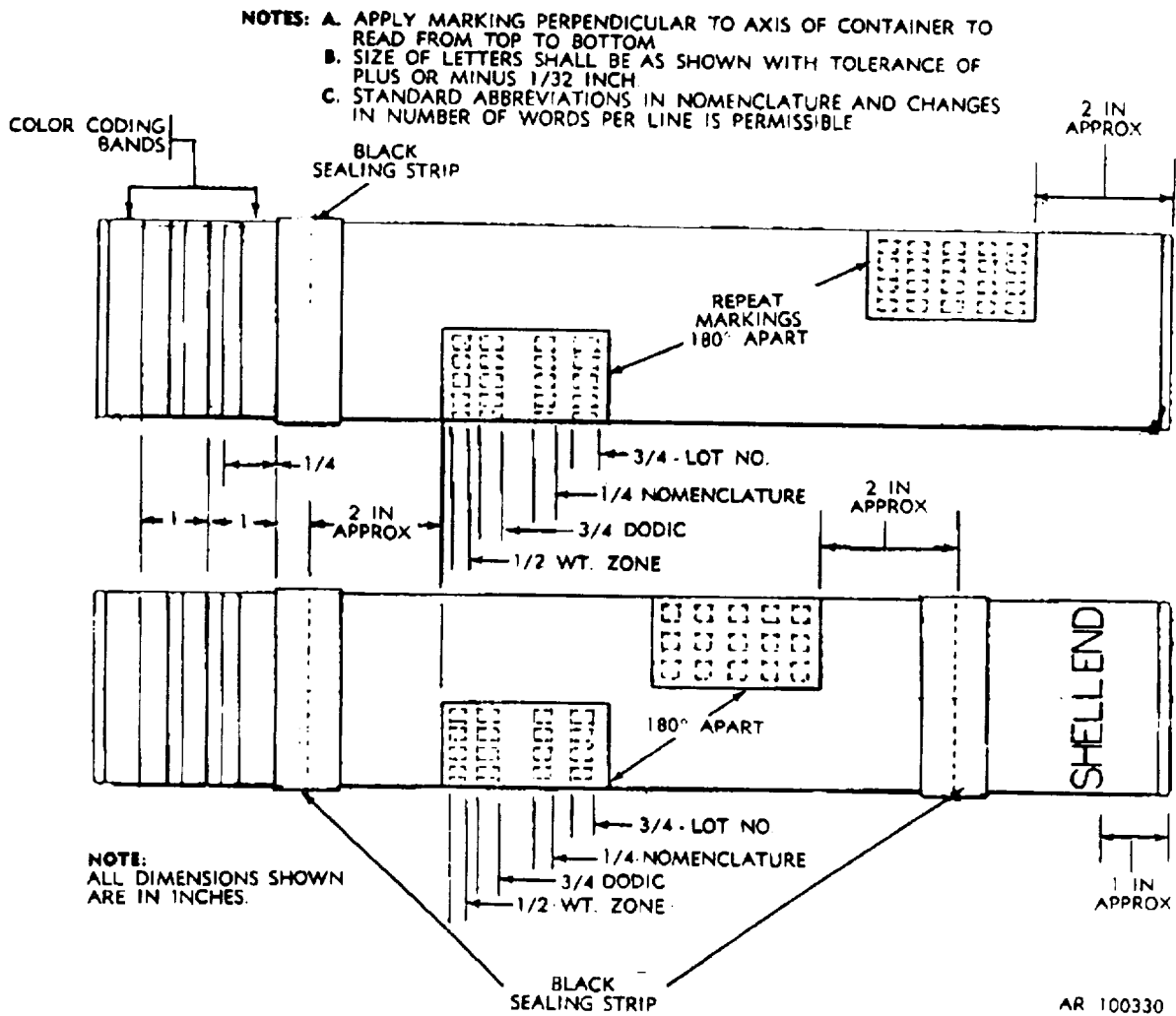

Figure C-1. Typical marking diagram for fiber containers.

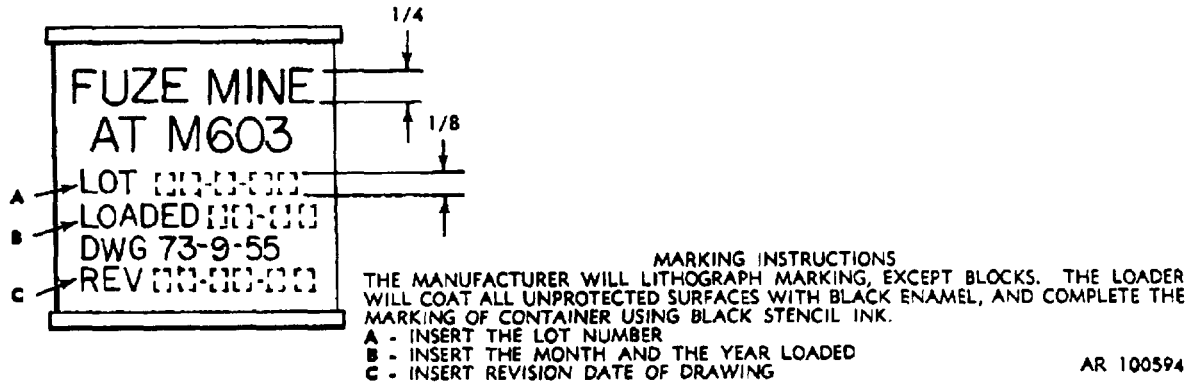

Figure C-2. Typical marking diagram for metal containers.

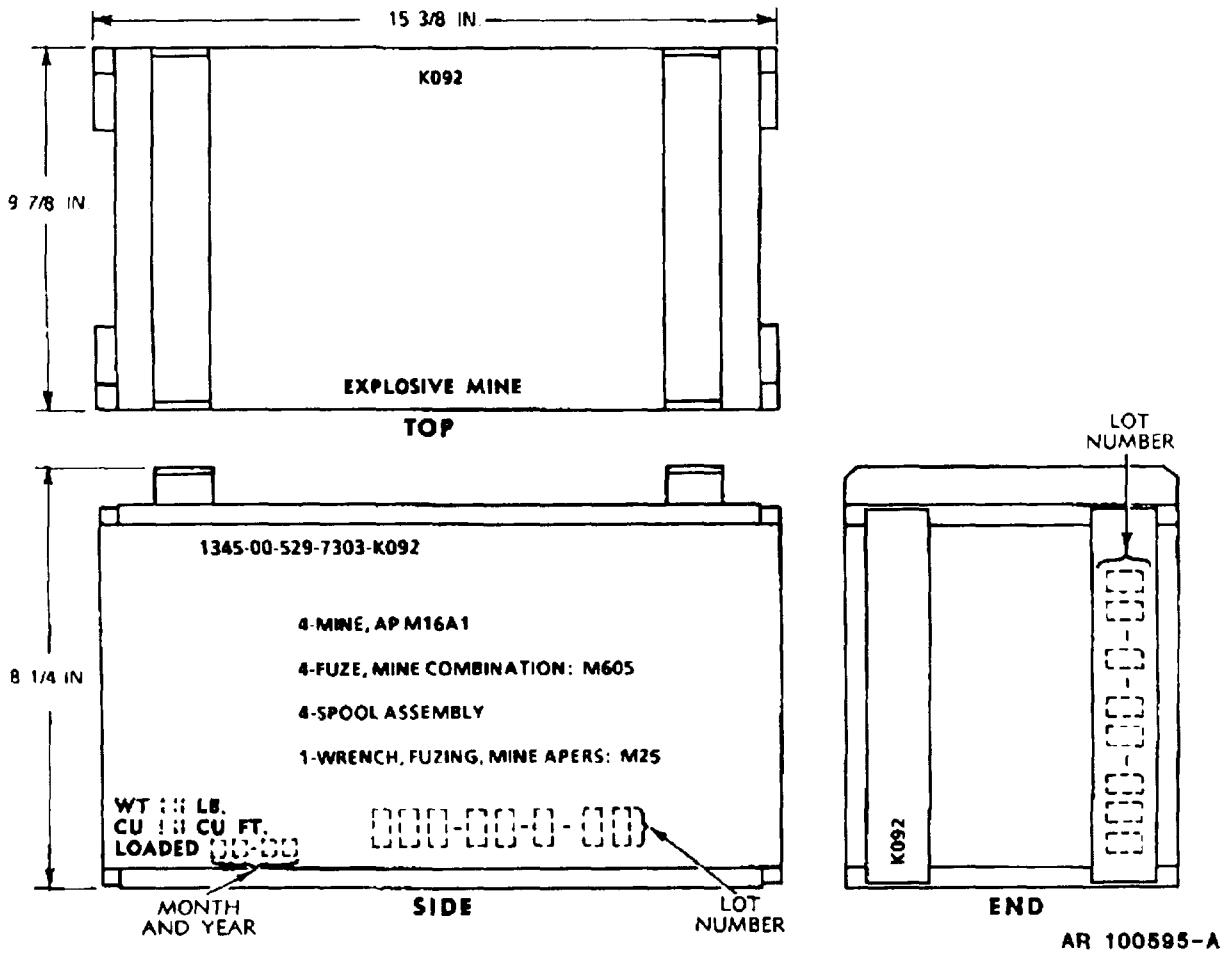
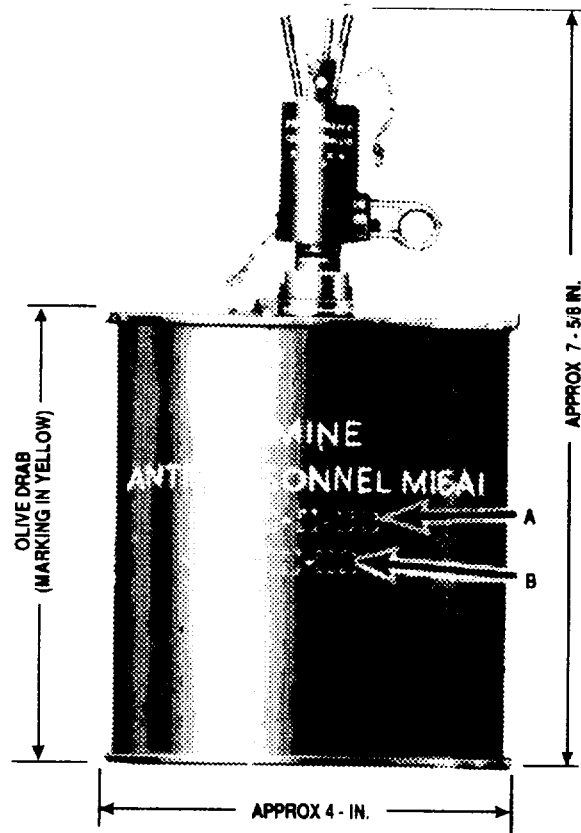

Figure C-3. Typical marking diagram for wooden boxes.



**MARKING DIAGRAM**

LOADING PLANT TO APPLY MARKING TO CONTAINER USING  
LETTERS 1/4 INCH HIGH WITH YELLOW NO. 3305 STENCIL INK.  
A - LOADERS LOT NUMBER  
B - DATE (MONTH AND YEAR) LOADED.

U  
AR100129-A

Figure C-4. Typical markings for service APERS mines.

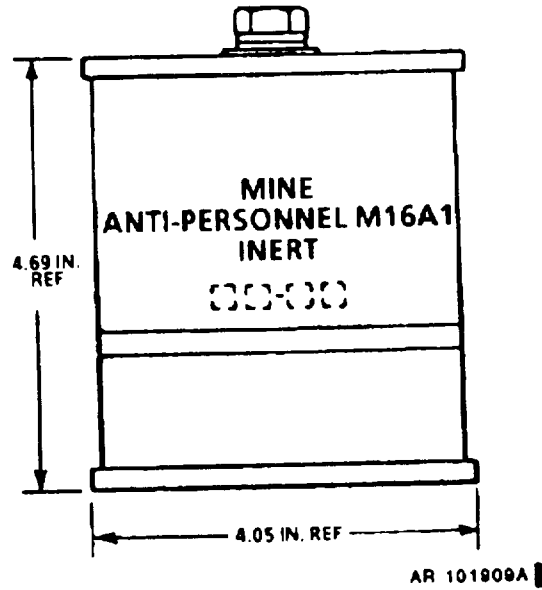

Figure C-5. Typical markings for practice APERS mines.

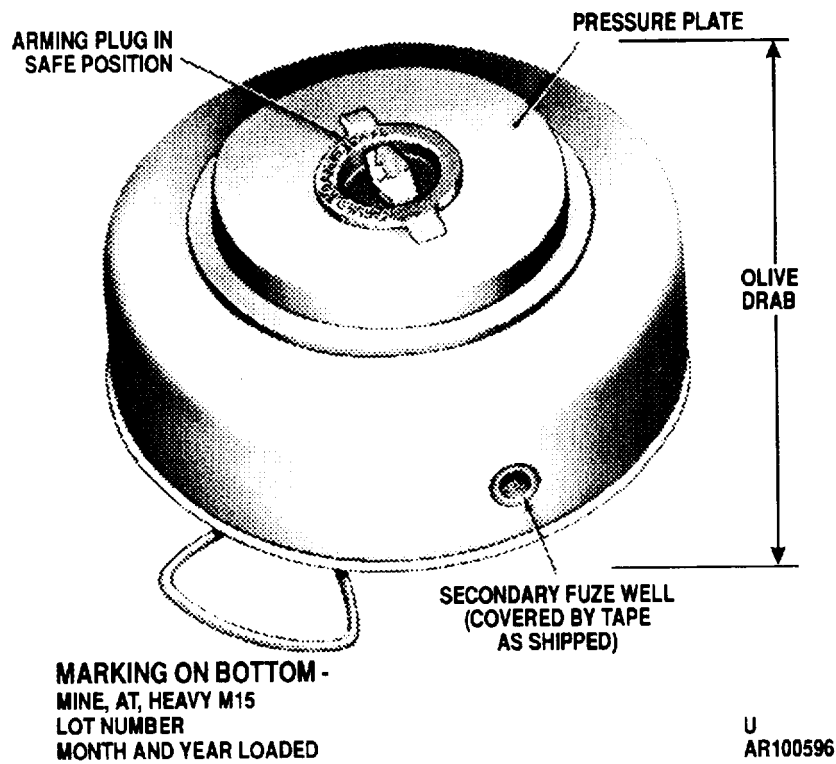

Figure C-6. Typical markings for service AT mines.

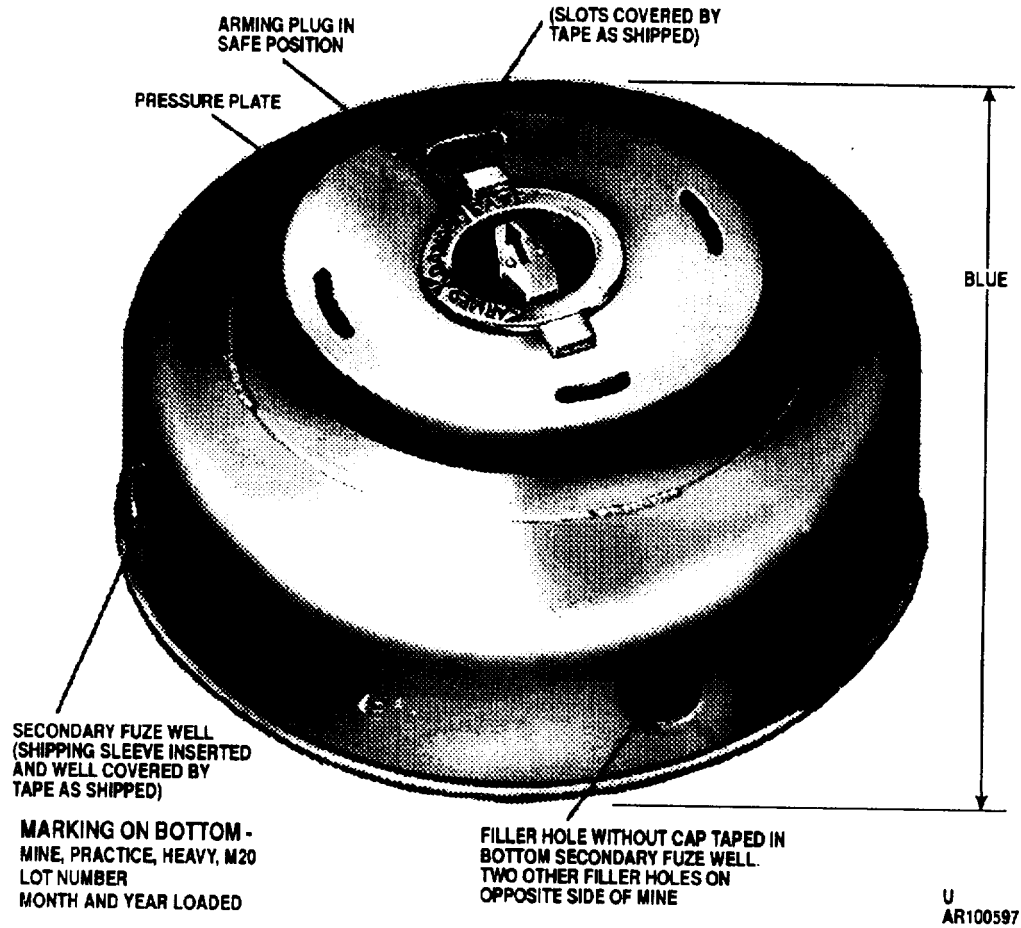

Figure C-7. Typical markings for practice AT mines

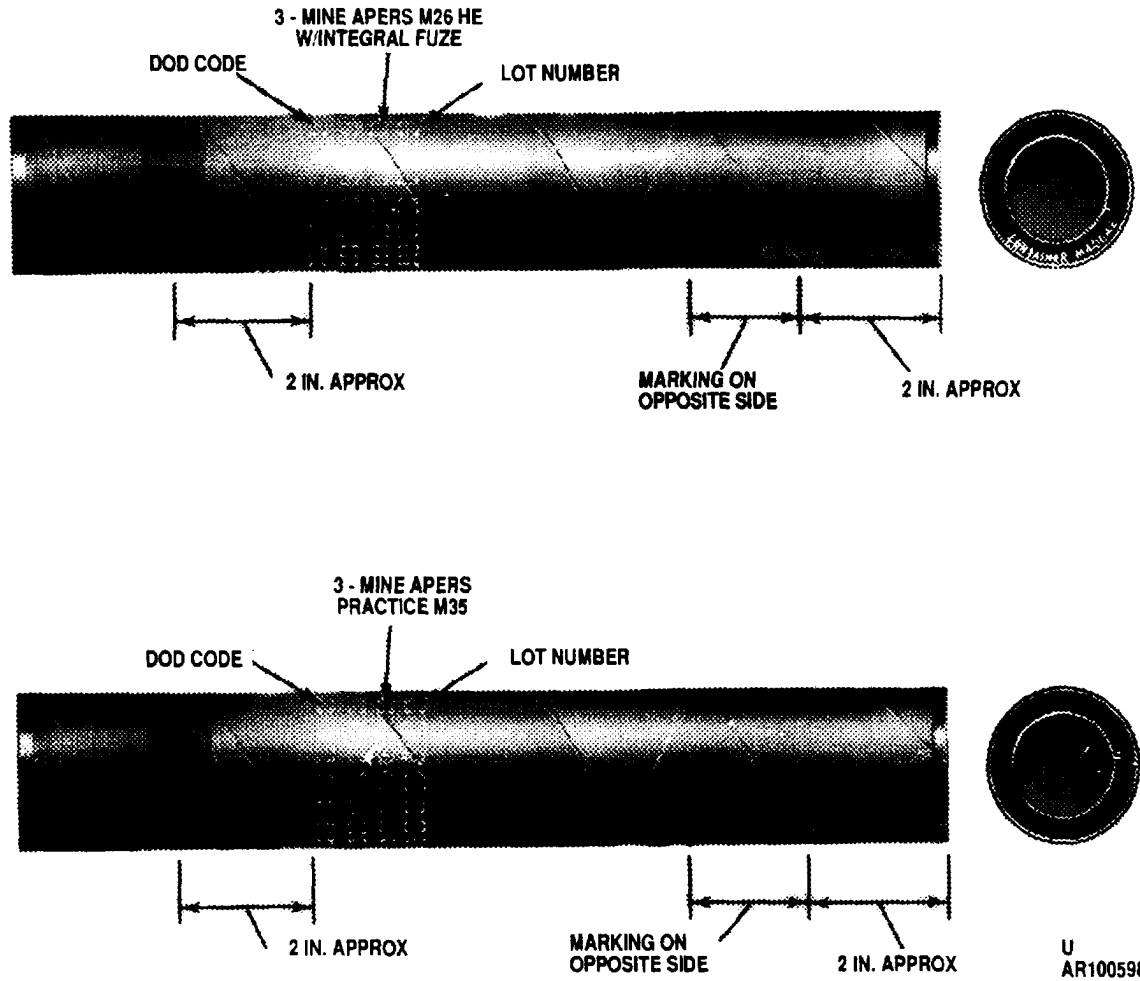
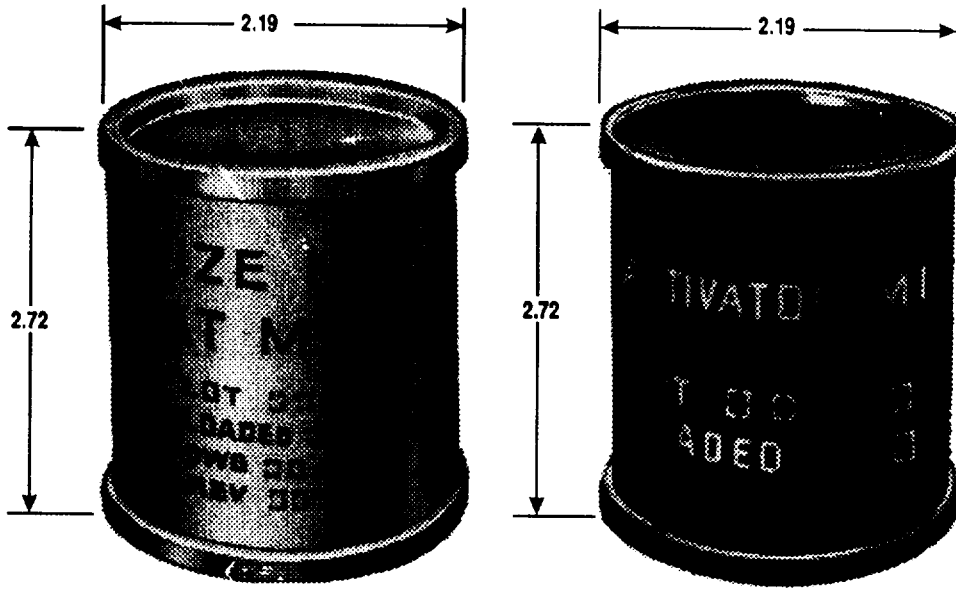
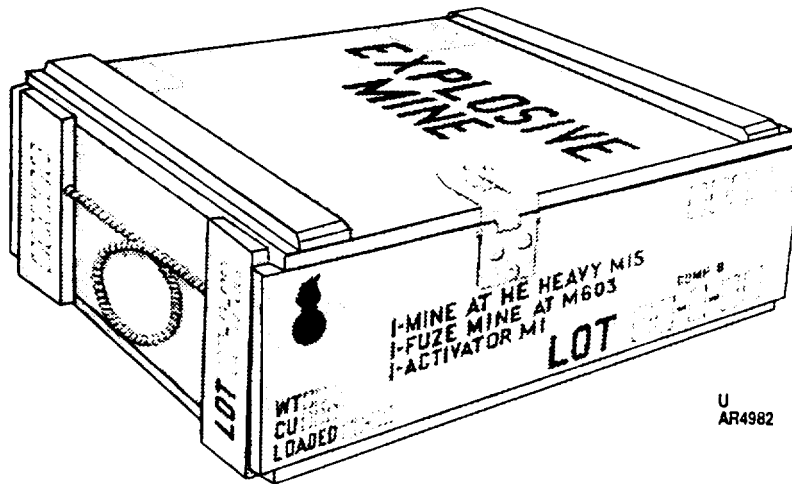

Figure C-8. Typical markings for fiber containers.



U  
AR100599

Figure C-9. Typical markings for metal contains.



U  
AR4982

Figure C-10. Typical markings for wooden boxes.



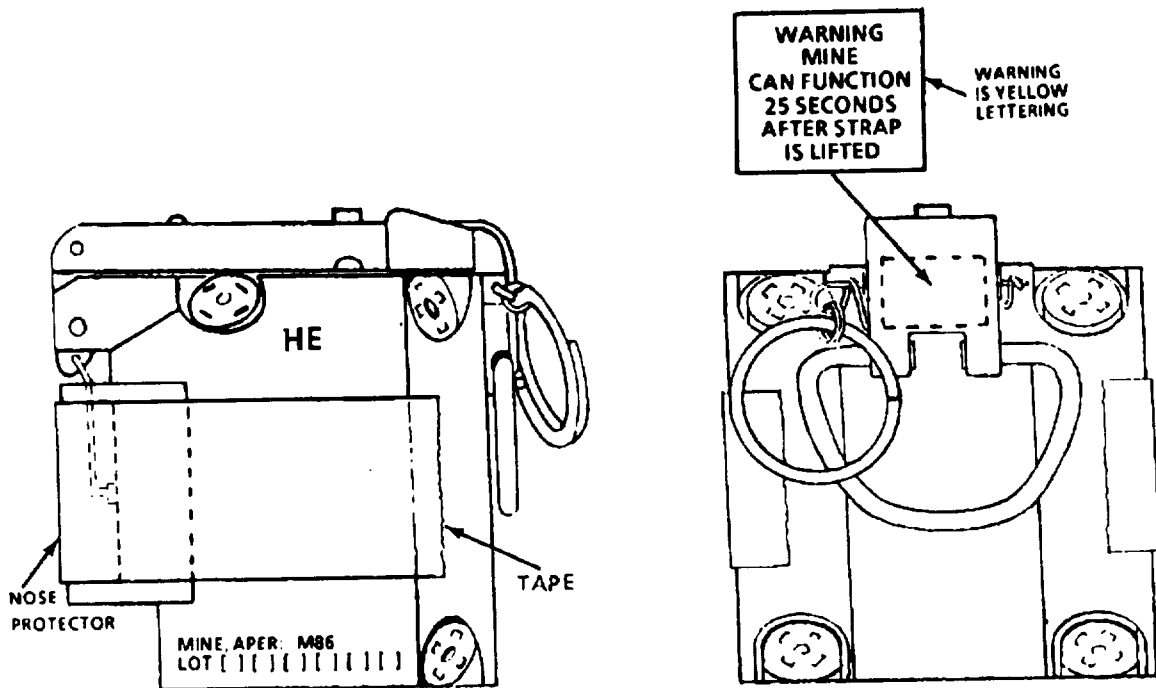

DIMENSIONS OF LETTERS AND NUMERALS 1/8 IN. OR 3/16 IN. USE LETTERS 1/4 IN. OR 3/8 IN. FOR HE MARKING EXCEPT WARNING IS BLACK

U  
AR 2692-A

Figure C-11. Typical markings for Mine, Antipersonnel: M86.

NOTES:

- 1- INSERT DEPARTMENT OF DEFENSE IDENTIFICATION CODE.
- 2- INSERT DESCRIPTIVE NOMENCLATURE.
- 3- INSERT LOT NUMBER.
- 4- INSERT QUANTITY [ ] [ ] .
- 5- MARKINGS ARE YELLOW

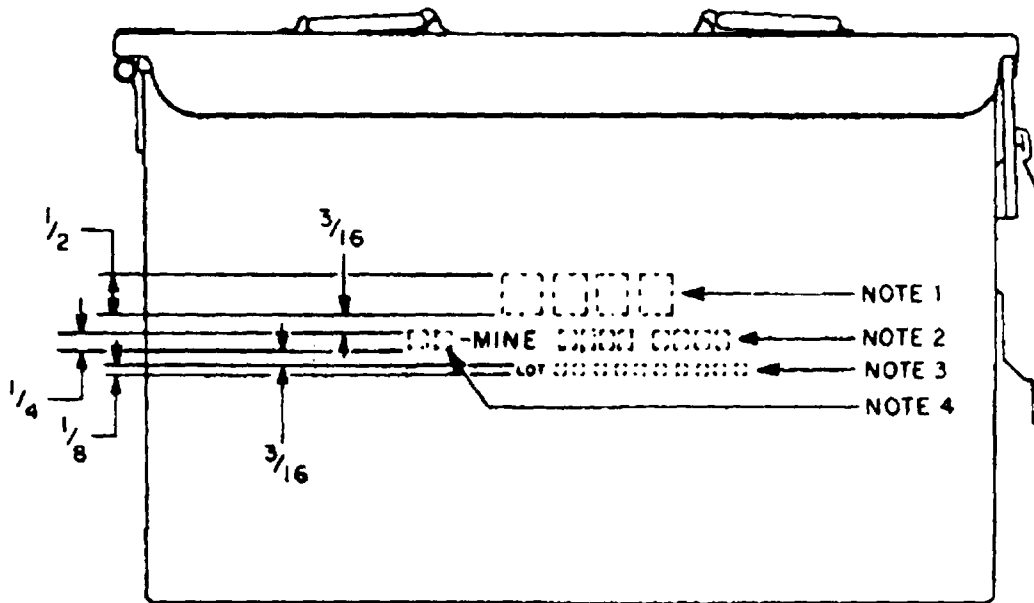

NOTE:  
ALL DIMENSIONS SHOWN  
IN INCHES

U  
AR 2663-A

Figure C-12. Typical markings for shipping and storage container, PA19.

By Order of the Secretary of the Army:

Official:

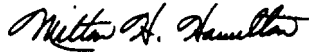

MILTON H. HAMILTON  
*Administrative Assistant to the  
Secretary of the Army*

05632

GORDON R. SULLIVAN  
*General, United States Army  
Chief of Staff*

Distribution:

To be distributed in accordance with DA Form 12-40-E, Block 1069, requirements for TM 9-1345-203-34.



<b>RECOMMENDED CHANGES TO PUBLICATIONS AND BLANK FORMS</b> For use of this form, see AR 25-30; the proponent agency is ODISC4.						Use Part II ( <i>reverse</i> ) for Repair Parts and Special Tool Lists (RPSTL) and Supply Catalogs/Supply Manuals (SC/SM).	DATE
TO: ( <i>Forward to proponent of publication or form</i> ) ( <i>Include ZIP Code</i> )						FROM: ( <i>Activity and location</i> ) ( <i>Include ZIP Code</i> )	
<b>PART I - ALL PUBLICATIONS (EXCEPT RPSTL AND SC/SM) AND BLANK FORMS</b>							
PUBLICATION/FORM NUMBER <b>TM 9-1375-225-12</b>						DATE <b>18 Jun 99</b>	TITLE <b>SOF Demo Kit, M303</b>
ITEM NO.	PAGE NO.	PARA-GRAPH	LINE NO.*	FIGURE NO.	TABLE NO.	RECOMMENDED CHANGES AND REASON <i>(Provide exact wording of recommended changes, if possible).</i>	
1	1-2	1.2.4				Change "Rock Island, IL 61201" to read "Aberdeen Proving Ground, MD 21010". Reason: Wrong Address.	
2	2-3			2-6		Add "LOCKWASHER" to the illustration. Reason: Missing from illustration.	
<i>* Reference to line numbers within the paragraph or subparagraph.</i>							
TYPED NAME, GRADE OR TITLE						TELEPHONE EXCHANGE/AUTOVON, PLUS EXTENSION	SIGNATURE

SAMPLE

**This Page Intentionally Left Blank**

<b>RECOMMENDED CHANGES TO PUBLICATIONS AND BLANK FORMS</b>						Use Part II ( <i>reverse</i> ) for Repair Parts and Special Tool Lists (RPSTL) and Supply Catalogs/Supply Manuals (SC/SM).	DATE
For use of this form, see AR 25-30; the proponent agency is ODISC4.							
TO: ( <i>Forward to proponent of publication or form</i> ) ( <i>Include ZIP Code</i> )						FROM: ( <i>Activity and location</i> ) ( <i>Include ZIP Code</i> )	
<b>LRED (AMSRD-AAR-AIL-LS)</b>							
<b>U.S. Army RDECOM, ARDEC</b>							
<b>Picatinny Arsenal, NJ 07806-5000</b>							
<b>PART I - ALL PUBLICATIONS (EXCEPT RPSTL AND SC/SM) AND BLANK FORMS</b>							
PUBLICATION/FORM NUMBER						DATE	TITLE
<b>TM 9-1345-203-34</b>						<b>29 Nov 93</b>	<b>DS and GS Maintenance Manual for Land Mines</b>
ITEM NO.	PAGE NO.	PARA-GRAPH	LINE NO.*	FIGURE NO.	TABLE NO.	RECOMMENDED CHANGES AND REASON <i>(Provide exact wording of recommended changes, if possible).</i>	
* Reference to line numbers within the paragraph or subparagraph.							
TYPED NAME, GRADE OR TITLE				TELEPHONE EXCHANGE/AUTOVON, PLUS EXTENSION		SIGNATURE	

<b>TO:</b> <i>(Forward direct to addressee listed in publication)</i> <b>LRED (AMSRD-AAR-AIL-LS)</b> <b>U.S. Army RDECOM, ARDEC</b> <b>Picatinny Arsenal, NJ 07806-5000</b>	<b>FROM:</b> <i>(Activity and location) (Include ZIP Code)</i>	<b>DATE</b>
--	--	-------------

**PART II - REPAIR PARTS AND SPECIAL TOOL LISTS AND SUPPLY CATALOGS/SUPPLY MANUALS**

PUBLICATION NUMBER			DATE	TITLE				
PAGE NO.	COLM NO.	LINE NO.	NATIONAL STOCK NUMBER	REFERENCE NO.	FIGURE NO.	ITEM NO.	TOTAL NO. OF MAJOR ITEMS SUPPORTED	RECOMMENDED ACTION

**PART III - REMARKS** *(Any general remarks or recommendations, or suggestions for improvement of publications and blank forms. Additional blank sheets may be used if more space is needed.)*

TYPED NAME, GRADE OR TITLE	TELEPHONE EXCHANGE/AUTOVON, PLUS EXTENSION	SIGNATURE
----------------------------	--	-----------



<b>RECOMMENDED CHANGES TO PUBLICATIONS AND BLANK FORMS</b> <small>For use of this form, see AR 25-30; the proponent agency is ODISC4.</small>						<small>Use Part II (reverse) for Repair Parts and Special Tool Lists (RPSTL) and Supply Catalogs/Supply Manuals (SC/SM).</small>	<small>DATE</small>
<small>TO: (Forward to proponent of publication or form) (Include ZIP Code)</small> <b>LRED (AMSRD-AAR-AIL-LS)</b> <b>U.S. Army RDECOM, ARDEC</b> <b>Picatinny Arsenal, NJ 07806-5000</b>						<small>FROM: (Activity and location) (Include ZIP Code)</small>	
<b>PART I - ALL PUBLICATIONS (EXCEPT RPSTL AND SC/SM) AND BLANK FORMS</b>							
<small>PUBLICATION/FORM NUMBER</small> <b>TM 9-1345-203-34</b>						<small>DATE</small> <b>29 Nov 93</b>	<small>TITLE</small> <b>DS and GS Maintenance Manual for Land Mines</b>
<small>ITEM NO.</small>	<small>PAGE NO.</small>	<small>PARA-GRAPH</small>	<small>LINE NO.*</small>	<small>FIGURE NO.</small>	<small>TABLE NO.</small>	<small>RECOMMENDED CHANGES AND REASON (Provide exact wording of recommended changes, if possible).</small>	
<small>* Reference to line numbers within the paragraph or subparagraph.</small>							
<small>TYPED NAME, GRADE OR TITLE</small>				<small>TELEPHONE EXCHANGE/AUTOVON, PLUS EXTENSION</small>		<small>SIGNATURE</small>	

<b>TO:</b> <i>(Forward direct to addressee listed in publication)</i> <b>LRED (AMSRD-AAR-AIL-LS)</b> <b>U.S. Army RDECOM, ARDEC</b> <b>Picatinny Arsenal, NJ 07806-5000</b>	<b>FROM:</b> <i>(Activity and location) (Include ZIP Code)</i>	<b>DATE</b>
--	--	-------------

**PART II - REPAIR PARTS AND SPECIAL TOOL LISTS AND SUPPLY CATALOGS/SUPPLY MANUALS**

PUBLICATION NUMBER			DATE	TITLE				
PAGE NO.	COLM NO.	LINE NO.	NATIONAL STOCK NUMBER	REFERENCE NO.	FIGURE NO.	ITEM NO.	TOTAL NO. OF MAJOR ITEMS SUPPORTED	RECOMMENDED ACTION

**PART III - REMARKS** *(Any general remarks or recommendations, or suggestions for improvement of publications and blank forms. Additional blank sheets may be used if more space is needed.)*

TYPED NAME, GRADE OR TITLE	TELEPHONE EXCHANGE/AUTOVON, PLUS EXTENSION	SIGNATURE
----------------------------	--	-----------

<b>RECOMMENDED CHANGES TO PUBLICATIONS AND BLANK FORMS</b> <small>For use of this form, see AR 25-30; the proponent agency is ODISC4.</small>						<small>Use Part II (reverse) for Repair Parts and Special Tool Lists (RPSTL) and Supply Catalogs/Supply Manuals (SC/SM).</small>	<small>DATE</small>
<small>TO: (Forward to proponent of publication or form) (Include ZIP Code)</small> <b>LRED (AMSRD-AAR-AIL-LS)</b> <b>U.S. Army RDECOM, ARDEC</b> <b>Picatinny Arsenal, NJ 07806-5000</b>						<small>FROM: (Activity and location) (Include ZIP Code)</small>	
<b>PART I - ALL PUBLICATIONS (EXCEPT RPSTL AND SC/SM) AND BLANK FORMS</b>							
<small>PUBLICATION/FORM NUMBER</small> <b>TM 9-1345-203-34</b>						<small>DATE</small> <b>29 Nov 93</b>	<small>TITLE</small> <b>DS and GS Maintenance Manual for Land Mines</b>
<small>ITEM NO.</small>	<small>PAGE NO.</small>	<small>PARA-GRAPH</small>	<small>LINE NO.*</small>	<small>FIGURE NO.</small>	<small>TABLE NO.</small>	<small>RECOMMENDED CHANGES AND REASON (Provide exact wording of recommended changes, if possible).</small>	
<small>* Reference to line numbers within the paragraph or subparagraph.</small>							
<small>TYPED NAME, GRADE OR TITLE</small>				<small>TELEPHONE EXCHANGE/AUTOVON, PLUS EXTENSION</small>		<small>SIGNATURE</small>	

<b>TO:</b> <i>(Forward direct to addressee listed in publication)</i> <b>LRED (AMSRD-AAR-AIL-LS)</b> <b>U.S. Army RDECOM, ARDEC</b> <b>Picatinny Arsenal, NJ 07806-5000</b>	<b>FROM:</b> <i>(Activity and location) (Include ZIP Code)</i>	<b>DATE</b>
--	--	-------------

**PART II - REPAIR PARTS AND SPECIAL TOOL LISTS AND SUPPLY CATALOGS/SUPPLY MANUALS**

PUBLICATION NUMBER			DATE	TITLE				
PAGE NO.	COLM NO.	LINE NO.	NATIONAL STOCK NUMBER	REFERENCE NO.	FIGURE NO.	ITEM NO.	TOTAL NO. OF MAJOR ITEMS SUPPORTED	RECOMMENDED ACTION

**PART III - REMARKS** *(Any general remarks or recommendations, or suggestions for improvement of publications and blank forms. Additional blank sheets may be used if more space is needed.)*

TYPED NAME, GRADE OR TITLE	TELEPHONE EXCHANGE/AUTOVON, PLUS EXTENSION	SIGNATURE
----------------------------	--	-----------



